

Town of Manchester, Connecticut

WATER AND SEWER

DEPARTMENT

RULES AND REGULATIONS



Effective Date: August 14, 2012

Adopted: August 14, 2012
Action #281-12

**TOWN OF MANCHESTER
WATER AND SEWER DEPARTMENT
RULES AND REGULATIONS**

TABLE OF CONTENTS

	Page
FORWARD	i
SECTION 1 – GENERAL	
1.01 GENERAL GUIDELINES	1
1.02 REFERENCES	2
1.03 DEFINITIONS	4
<u>SECTION 2 – WATER DISTRIBUTION SYSTEM</u>	
2.01 OWNERSHIP AND RESPONSIBILITIES	20
2.01.01 Manchester Water Department	20
2.01.02 Owner	21
2.01.03 Developer	23
2.02 WATER SERVICE	23
2.02.01 General	23
2.02.02 Domestic Service	23
2.02.03 Private Fire Protection	24
2.02.04 Public Fire Protection	25
2.02.05 Water Supply Pressure and Continuity	25
2.02.06 Cross Connection	26
<u>SECTION 3 – SANITARY SEWER COLLECTION SYSTEM</u>	
3.01 OWNERSHIP AND RESPONSIBILITIES	29
3.01.01 Manchester Sewer Department	29
3.01.02 Owner	30
3.01.03 Developer	31
3.02 SANITARY SEWER SERVICE	32

Water and Sewer Department – Rules and Regulations

3.02.01	General	32
3.02.02	Domestic Wastewater	33
3.02.03	Industrial Wastewater	33
3.02.04	Discharge Requirements	34
3.02.05	Discharge Limits	35
3.02.06	Rejection and/or Pretreatment of Waste	38

SECTION 4 – CUSTOMER SERVICE

4.01	BILLING	39
4.01.01	General	39
4.01.02	Adjustment of Bills	40
4.02	TERMINATION OF SERVICE	40
4.03	METERS AND METER TESTING	41

SECTION 5 – PERMITS AND PROGRAMS

5.01	GENERAL	44
5.02	WATER AND SEWER PERMIT	44
5.03	DISCHARGE PERMIT	47
5.04	FATS, OILS AND GREASE (FOG) PERMIT	47
5.05	SEPTAGE DISCHARGE PERMIT	48
5.06	HYDRANT METER PERMIT	49
5.07	PASSIVE RECREATION PROGRAM.....	49
5.07.01	General	49
5.07.02	Responsibilities	50
5.07.03	Group and Special Event Permits.....	50
5.07.04	Violations	51
5.08	CORDWOOD PERMIT	51

SECTION 6 – SYSTEM EXTENSIONS

6.01	GENERAL	52
6.02	SYSTEM EXTENSION AGREEMENT	53
6.03	REIMBURSEMENT OF SYSTEM EXTENSION COSTS	54
6.03.01	General	54
6.03.02	Direct Payment	55
6.03.03	Materials or In-Kind Services	55
6.03.04	Assessments	55
6.04	LEVYING OF ASSESSMENTS	55
6.04.01	Procedures	55
6.04.02	Methodology	57
6.04.03	Payment Options	57
6.05	SYSTEM EXTENSION CHARGE	58

SECTION 7 – VIOLATIONS

7.01	PENALTIES	59
------	-----------------	----

SECTION 8 – DESIGN AND CONSTRUCTION

8.01	TECHNICAL AND MATERIAL STANDARDS	60
------	--	----

APPENDIX

FIGURE 1	WATER DISTRIBUTION SYSTEM
FIGURE 2	WATER SUPPLY SYSTEM
FIGURE 3	WATER METER WITH ASSOCIATED READING EQUIPMENT
FIGURE 4	PRIVATE FIRE PROTECTION SYSTEM
FIGURE 5	IRRIGATION SERVICE
FIGURE 6	SANITARY SEWER COLLECTION SYSTEM
FIGURE 7	SANITARY SEWER LATERAL

FORWARD

The Town of Manchester Water and Sewer Department has set forth the following Rules and Regulations in writing to establish the guidelines and administrative procedures of the Department that ensures that all individuals, developers and contractors doing business with the Department are treated in a uniform manner.

These Rules and Regulations are considered to be formal policies of the Department and are required to be followed by any customer, property owner, developer, contractor, corporation or individual doing business with the Department. When any rule, regulation or policy is subject to interpretation, the interpretation shall be made by the Department.

The Rules and Regulations have been developed by the Department's staff and adopted by the Board of Directors on Tuesday, August 14, 2012 in accordance with Chapter 12, Section 12-1 of the Charter of the Town of Manchester. The effective date of these Rules and Regulations is August 14, 2012.

SECTION 1 – GENERAL

1.01 GENERAL GUIDELINES

These Rules and Regulations may be modified from time to time by the Town of Manchester Water and Sewer Department to comply with changes in Federal, State and local laws and/or regulations as well as industry standards. Any minor modifications shall be in writing and incorporated in the published set of Rules and Regulations. Any policy modifications or re-writing of the Rules and Regulations in their entirety must be approved by the Board of Directors.

The Town of Manchester Water and Sewer Department shall be the sole purveyor of public water and provider of sanitary sewer service in the areas designated as the Town of Manchester's Water Service Area and/or Sanitary Sewer Service Area, respectively. No person may, without written permission of the Department, supply potable water or sanitary sewer service to another individual on either a temporary or permanent basis.

The Town of Manchester Water and Sewer Department may curtail or suspend the use of water and/or sanitary sewer service for any actions inconsistent with the Rules and Regulations contained herein and/or any other applicable statutes and regulations. The Department will not be liable for any losses incurred as a result of the curtailment or suspension of water service and/or sanitary sewer service.

The Town of Manchester Water and Sewer Department will administer its infrastructure. No other person, customer, contractor, developer or individual shall be allowed to operate said facilities. The Department may assist in the operation of private facilities. Such assistance may be subject to a charge. The Department does not assume any liability for the operation of private facilities.

Customers must allow employees or authorized representatives of the Town of Manchester Water and Sewer Department to have reasonable access to their premises for purpose of reading, testing, installing, replacing and repairing meters and/or Backflow Prevention Devices (BFDs); inspecting all plumbing connections, fixtures and mains; performing cross connection inspections; collecting water and/or sanitary sewer discharge samples; operating, maintaining and repairing the water distribution system and/or sanitary sewer collection system and other purposes that may be necessary under these Rules and Regulations.

Unauthorized use of, tampering with or causing degradation to the water distribution system, Water Treatment Plant (WTP), the sanitary sewer collection system and/or the Water Pollution Control Facility (WPCF) may result in prosecution in accordance with the applicable Federal, State and local laws, regulations and ordinances and the Rules and Regulations contained herein.

These Rules and Regulations are intended to establish in writing the methods and procedures to be utilized in conducting business with the Department. Many of these Rules and Regulations form the basis for current policies and procedures of the Department. The adoption of these Rules and Regulations shall not require existing conditions that are not in compliance to be remedied immediately. These conditions currently in existence that do not comply with these Rules and Regulations, as a general rule, do not need to be brought into compliance until an activity takes place that would require an action, which then must bring the conditions into compliance. Furthermore, the adoption of these Rules and Regulations shall not affect those water and sewer permits applied for and/or issued prior to the effective date of these Rules and Regulations. Finally, all operational practices set forth in these Rules and Regulations apply to all parties upon the effective date of adoption by the Board of Directors.

The lack of validity of any section, clause, sentence, or provision of these Rules and Regulations shall not affect the validity of any other part of these Rules and Regulations.

Should any individual disagree with decisions resulting from the implementation of the policies set forth herein, that individual may appeal said decisions by placing his/her concerns in writing and submitting them to the Water and Sewer Administrator for review. The Administrator will review the appeal and render a written decision. Appeal of the Administrator's decision can only be made to the General Manager. Such an appeal shall be made in writing. The General Manager will set a time for a hearing on the matter. The decision of the General Manager shall be final.

1.02 REFERENCES

These Rules and Regulations may make reference to one or more of the following publications:

- “The Charter of the Town of Manchester”, as amended;

Water and Sewer Department – Rules and Regulations

- “Code of Ordinances” as prepared by the Town of Manchester, as amended;
- “General Statutes of Connecticut”, as amended;
- Department of Energy and Environmental Protection – General and Individual Permits;
- “Water Pollution Control Act (Clean Water Act)” as amended;
- “Toxic Substances Control Act” as amended;
- “Resource Conservation and Recovery Act” as amended;
- “Department of Public Health - Public Health Code”, as amended;
- “Department of Public Utility Control Regulations”, as amended;
- “American Water Works Association Standards”, as amended;
- “American Water Works Association – Manual M6 - Water Meters”, as amended;
- “Call Before You Dig – Excavator’s Manual”, as amended;
- “Town of Manchester - Water Supply Plan”, as amended;
- “Hydraulic and Water Quality Study”, as amended;
- “Standard Methods for the Examination of Water and Wastewater”, as amended;
- “Town of Manchester – Schedule of Rates, Charges and Fees”, as amended;
- “Town of Manchester, Connecticut – Public Improvement Standards”, as amended.
- All water and/or sanitary sewer agreements that exist between the Town of Manchester and various towns, agencies, developers and individuals.

1.03 DEFINITIONS

Wherever used in these Rules and Regulations, the following terms shall have the indicated meanings, which shall be applicable to both the singular and plural thereof:

“Abandonment of Water Service”

The discontinuance of a fire service or domestic service at the water distribution main.

“Administrator”

The administrator of the Town of Manchester Water and Sewer Department, as defined in the Town Charter or his/her designee.

“Agent”

Authorized representative of the Town of Manchester.

“Apartment Building”

A structure containing four (4) or more individual dwelling units.

“Applicant”

Any person or entity requesting water and/or sanitary sewer service.

“Approved”

Determined by the Town of Manchester Water and Sewer Department as satisfactory and meeting Department and/or Town of Manchester standards.

“Assessment”

A charge levied by the Town of Manchester Board of Directors against a property that benefits from a system extension or improvement.

“AWWA”

The American Water Works Association.

“Backflow”

The reversal of the normal flow of water or other liquids caused by back pressure or back siphonage.

“Backflow Prevention Device (BFD)”

A device installed on a water service pipe or fire service that protects the public water supply from backflow.

“Biochemical Oxygen Demand”

The amount of oxygen required by bacteria while stabilizing decomposable organic matter under aerobic conditions for five (5) days as determined in accordance with the procedures set forth in the “Standard Methods for the Examination of Water and Wastewater”, latest revision.

“Board of Directors”

The Town of Manchester Board of Directors.

“Booster Pump System”

A collection of devices and mechanisms used to increase or maintain pressure in a water distribution system.

“Building Drain”

The lowest horizontal piping of the building drainage system that extends approximately five (5) feet beyond the walls of the building and conveys sewage to the building sewer (See Appendix - Figure #7).

“Building Sewer”

The piping that extends from the end of the building drain and conveys sewage to the sanitary sewer main (See Appendix - Figure #7).

“Categorical Pretreatment Standards”

National Categorical Pretreatment Standards or Pretreatment Standards.

“CBYD”

Call Before You Dig.

“Chargeable Work or Repairs”

Services, labor, equipment and materials provided by the Town of Manchester Water and Sewer Department.

“Chimney”

A section of sanitary sewer main that is vertical, perpendicular to the sanitary sewer main, and is used to connect a sanitary sewer lateral to a sanitary sewer main when a significant difference in elevation between the two exists.

“Clean Water Act”

See “Water Pollution Control Act”.

“Combined Service”

A single water service pipe that provides fire service and domestic service.

“Combined Sewer”

A sanitary sewer main that receives both sewage and storm/surface water discharges.

“Commissioner”

The Commissioner of the Connecticut Department of Energy and Environmental Protection.

“Compatible Pollutant”

Biochemical oxygen demand, suspended solids, pH, and fecal coliform bacteria plus any additional pollutants identified in the NPDES permit for the Town’s WPCF, where the WPCF is designed to treat and has the capability and capacity to treat such pollutants as required by its NPDES permit.

“Contact Person”

The individual responsible for overseeing the daily operation of a food preparation establishment or an industrial/commercial enterprise, who is responsible for the establishment’s compliance with the FOG or Industrial Pretreatment Program as established herein.

“Cooling Water”

Process water used for cooling purposes to which the only pollutant added is heat and which has characteristics such that it may be discharged to a natural outlet in accordance with Federal, State and local laws and regulations.

“Corporation Stop”

The device used to connect the water service pipe to the water distribution main (See Appendix - Figure #2).

“Cross Connection”

Any actual or potential connection between a public water supply and any other source or system through which it is possible to introduce into the water supply any contaminating or polluting agent.

“Curb Box”

A vertical casting and a cover placed over the curb stop and rod extending to the ground surface to allow access to the curb stop (See Appendix – Figure #2).

Water and Sewer Department – Rules and Regulations

“Curb Stop”

The valve on the domestic service, located on public property or at the limit of the Town Right of Way/Easement, between the main and the point of utilization (See Appendix - Figure #2).

“Customer”

The person contracting for water and/or sanitary sewer service.

“DEEP”

Connecticut Department of Energy and Environmental Protection.

“Department”

The Town of Manchester Water and/or Sewer Department. May be used to designate an individual, department, or both in combination.

“Department’s Land”

Land owned by the Town of Manchester, the use of which is under the jurisdiction and control of the Town of Manchester Water and Sewer Department.

“Developer”

Any person who is extending the water distribution system, water supply system or sanitary sewer collection system.

“Disputed Bill”

A bill that is contested with respect to its validity.

“Domestic Service”

A water service pipe utilized for all purposes other than fire service.

“Domestic Wastewater”

Wastewater consisting of water and human excretions or other waterborne wastes discharged incidental to the occupancy of a residential dwelling or from employee/public washrooms in institutions, businesses, or industrial establishments.

“Domestic Wastewater System”

Pipes within a structure that convey wastewater from sanitary facilities to the building drain (See Appendix - Figure #7).

“Domestic Water System”

Pipes, other than a fire service, within a structure that convey water from the water service pipe to the points of utilization within the structure (See Appendix - Figure #2).

“Dwelling”

A building or part of a building, containing living, sleeping, eating, cooking and sanitary facilities for occupancy by one or more families.

“Dwelling Unit”

A single unit providing complete, independent living facilities for one or more persons, including permanent provisions for living, sleeping, eating, cooking and sanitation.

“Easement”

An interest in land, owned by another, deeded to the Town of Manchester or the Town of Manchester Water and Sewer Department for the limited purposes described therein.

“Eighth Utilities District (the District)”

A corporate and body politic within the Town of Manchester that provides fire protection and/or sanitary sewer service within areas set forth in a 1988 agreement between the Town and the District.

“Exception Meter”

A water meter used to record the amount of water consumed that will not be charged a sewer use rate.

“Fats, Oils or Grease (FOG)”

Any fats, oils, and/or grease generated from the food preparation process.

“Fire Department Connection”

An inlet equipped with one or more couplings to which a fire hose can be attached and through which water can be delivered to a fire sprinkler system.

“Fire Flow Test”

A test for the purpose of measuring flow from a hydrant and/or determining the hydraulic characteristics of the localized water distribution/supply system(s).

“Fire Hydrant”

A device, connected to a water main, to which fire hose(s) may be connected for the purpose of extinguishing fires.

“Fire Service”

A water service pipe used to purvey water to fire suppression facilities (See Appendix - Figure #4).

“Fire Sprinkler System”

An integrated system of underground and overhead piping designed to provide fire protection for a building or structure (See Appendix - Figure #4).

“FOG Management Equipment”

FOG interceptors, automatic grease recovery units, and/or alternate FOG management equipment that has been approved, installed and is operating in accordance with the requirements set forth in these Rules and Regulations.

“Food Preparation Establishments”

Any Class III or Class IV food preparation establishment as defined by the State of Connecticut Public Health Code or any other facility discharging fats, oils and/or grease above the effluent limits set forth in the “General Permit for the Discharge of Wastewater Associated with Food Preparation Establishments”. Such facilities include, but are not limited to, restaurants, hotel kitchens, hospital kitchens, school kitchens, bars, factory cafeterias, retail bakeries and clubs.

“Frontage”

The length of a lot’s perimeter boundary that abuts or is adjacent to either a Town Right of Way or an existing or proposed public or private street.

“Garbage”

Animal or vegetable waste resulting from the handling, preparation, cooking, or serving of food.

“General Manager”

The Town of Manchester General Manager.

“General Statutes of Connecticut (GSC)”

The legislative statutes of the State of Connecticut.

“Grinder Pump”

A pump facility that collects and pulverizes sewage for the purpose of discharging it through a sanitary sewer force main to a sanitary sewer main.

“Holding Tank”

Tanks such as privies, vessels, chemical toilets, campers, trailers, septic tanks, and septage hauling trucks used to temporarily store waste.

“Hydrant Lead”

The pipe, valve and fittings that run between a main and a fire hydrant.

“Hydrant Meter”

A device attached to a hydrant used to measure water for the purpose of calculating usage.

“Hydrant Meter Permit”

A written permit, obtained for the use of a hydrant meter.

“Inch Foot Charge”

The rate used to compute the annual fire protection charge billed to municipalities.

“Incompatible Pollutant”

All pollutants other than those defined as compatible pollutants.

“Industrial Wastewater”

Wastewater, other than domestic wastewater, discharged from institutions, businesses, or industrial establishments.

“Infrastructure Improvement Plan”

Proposed infrastructure improvements based upon current engineering studies commissioned by the Town of Manchester Water and Sewer Department.

“In-Kind Services”

The contribution of labor and/or equipment from Departmental functions such as, but not limited to, construction, engineering, inspection and administration.

“Irrigation Service”

A water service pipe used to supply water to an irrigation system (See Appendix - Figure #5).

“Irrigation System”

An underground piping system used for irrigation purposes (See Appendix - Figure #5).

“Lateral”

See “Sanitary Sewer Lateral”.

“Licensed Professional”

An individual (i.e. engineer, surveyor, architect, operator, etc.) registered with and authorized by the State of Connecticut to provide services to the public in his/her area of expertise.

“Limited Service Agreement”

An agreement between the Town of Manchester Water and Sewer Department and the Owner, defining the conditions covering the purveyance of public water.

“Maintain”

The act of performing certain tasks for the purpose of preserving a facility’s usable condition.

“Meter”

Recording device and reading system used to measure flow and/or quantity. (See Appendix - Figure #3).

“Meter Pit”

A subsurface enclosure installed outside of buildings that houses water meters or sanitary sewer meters and other related facilities.

“Meter Setting”

The pipe, valves, fittings and appurtenances necessary for the installation of a meter on a water service pipe.

“Multi-family Dwelling (Apartment)”

A building, containing four or more individual dwelling units.

“Municipality”

The Town of Manchester, the Town of Manchester Water and Sewer Department or its agents.

“National Pollutant Discharge Elimination System (NPDES) Permit”

A permit issued by the Connecticut Department of Energy and Environmental Protection, on behalf of the Environmental Protection Agency, to the Town, pursuant to the Clean Water Act, for the purpose of operating its WPCF.

“NFPA”

National Fire Protection Association.

“Normal Working Hours”

Field Personnel...7:00 AM – 3:30 PM, Monday through Friday, except holidays.

All other personnel... 8:00 AM – 4:30 PM, Monday through Friday, except holidays.

“Notification”

Written confirmation and/or authorization from the Town of Manchester.

“On-site Sanitary Sewer Disposal System (Septic System)”

A collection of devices or mechanisms, usually subsurface in nature, that provides an environment for the biological treatment of sewage.

“Operate”

To direct or control the functioning of.

“Own”

To hold title to a property or premises.

“Owner”

The person or legal entity holding title to the property or premises connected to or proposed to be connected to the water distribution system and/or the sanitary sewer collection system.

“Parcel”

A tract or plot of land.

“Passive Recreation”

Activities consisting of walking, hiking, jogging, orienteering, cross-country skiing and other legal uses as allowed under Section 25-43c of the GSC .

“Person”

Any individual, partnership, co-partnership, firm, company, corporation, association, joint stock company, trust, estate, governmental entity or any other legal entity or their legal representatives, agents, or assigns. The masculine gender shall include the feminine; the singular the plural where indicated by context.

“pH”

The negative logarithm of the hydrogen ion concentration.

“PHC”

Department of Public Health - Public Health Code, as amended.

Water and Sewer Department – Rules and Regulations

“Pipe(s)”

A tube or hollow body used for the purpose of conveying water or sewage. This term is meant to be generic in its description and does not imply ownership (i.e. public or private) unless otherwise modified.

“Pollutant”

Any constituent that hinders the beneficial use of water and/or poses a threat to human health or the environment.

“POTW”

Privately Owned Treatment Works. See “Water Pollution Control Facility”.

“Premise”

A single parcel or combination of parcels of land with one or more structures.

“Pretreatment or Treatment”

The reduction or elimination of pollutants or the alteration of pollutant properties in sewage to a less harmful state prior to, or in lieu of discharging or otherwise introducing such pollutants into the sanitary sewer collection system.

“Private Fire Protection System”

All private mains, hydrants, and appurtenances utilized for the purpose of fire protection (See Appendix - Figure #4).

“Private Sanitary Sewer Main”

All mains not incorporated into the Town’s sanitary sewer collection system.

“Private Water Mains”

All mains not incorporated into the Town’s water distribution system.

“PRV”

Pressure Reducing Valve.

“Public Fire Protection System”

All public mains, hydrants, and appurtenances utilized for the purpose of fire protection (See Appendix - Figure #4).

“Pump Station”

A system of devices and mechanisms used to collect and discharge sewage from a point of lower elevation to a point of higher elevation.

“PURA”

(Connecticut) Public Utilities Regulation Authority.

“Renewal”

The act of restoring, in its entirety, to the original condition or to a current standard as opposed to repairing a portion thereof.

“Repair”

The act of restoring to a sound condition.

“Replacement”

The act of replacing, in its entirety, as opposed to replacing a portion thereof.

“Residential Fire Sprinkler System”

A fire sprinkler system that meets the definition of fast response, has been designed for the protection of dwelling units and enhanced survivability in the room of fire origin; all in accordance with the provisions of NFPA13.

“Resource Conservation and Recovery Act (RCRA)”

The Federal law that regulates the generation, transportation, treatment, storage, and disposal of hazardous wastes (US Code: Title 42 – Chapter 82 – Subchapter I – Section 6901 et seq.).

“Right of Way”

A legal right of passage over and/or use of another person's property or property owned by the Town.

“RPD”

Reduced Pressure Principle Backflow Device.

“Saddle”

A fitting used to connect either a sanitary sewer lateral to the sanitary sewer main or a water service pipe to a water main. This type of fitting wraps around the main.

“Sanitary Sewer Collection System”

The sanitary sewer mains, manholes, pump stations and appurtenances, exclusive of sanitary sewer laterals (e.g. building sewers and building drains), that collect and convey sewage to the WPCF and are owned, operated, maintained, repaired and replaced by the Town of Manchester Water and Sewer Department; located on public property, in the Town Right of Way or in an easement approved by and deeded to the Town of Manchester Water and Sewer Department for its use (See Appendix - Figure #6).

“Sanitary Sewer Force Main”

A sanitary sewer main designed to convey sewage under pressurized conditions.

“Sanitary Sewer Lateral”

The piping, inclusive of building sewers and building drains, that conveys sewage to a sanitary sewer main (See Appendix - Figure #7).

“Sanitary Sewer Main(s)”

Sewer pipes, exclusive of sanitary sewer laterals (e.g. building sewers and building drains), used for the purpose of collecting and conveying sewage.

“Sanitary Sewer Meter”

Recording device and reading system used to measure the quantity of sewage passing through a sanitary sewer main.

“Sanitary Sewer Permit”

Document issued by the Town of Manchester Water and Sewer Department, authorizing work to be performed on the sanitary sewer collection system and/or any sanitary sewer lateral.

“Sanitary Sewer Service”

The collection of sewage.

“Sanitary Sewer Service Area”

The area as defined by the political boundaries of the Town of Manchester, including those areas defined by any inter-town sanitary sewer agreements, minus the sanitary sewer service area of the Eighth Utilities District as defined by the 1988 agreement between the District and the Town.

“Schedule of Rates, Charges and Fees”

A list, established by the Town of Manchester Board of Directors, of all rates, charges and fees utilized by the Town of Manchester Water and Sewer Department for connection to, and use of, the water distribution system, sanitary sewer collection system and for other miscellaneous work and services.

“Seasonal Meters”

Meters not installed for year round use.

“Septage”

The liquids and solids which are removed from a holding tank used to store or treat domestic sewage.

Water and Sewer Department – Rules and Regulations

“Sewage”

Any combination of domestic and industrial wastewater.

“Single-family Dwelling”

A building containing one dwelling unit.

“Slug”

Any sudden or excessive discharge to the sanitary sewer collection system which may exceed permitted levels either in terms of pollutant concentration and/or instantaneous flow rate in such a manner as to adversely affect either the sanitary sewer collection system and/or the WPCF.

“Storm Sewer”

A sewer that collects and conveys storm water or groundwater.

“Storm Water”

Water that consists of the runoff or discharge of rain, melted snow or other water from such facilities as, but not limited to, parking lots, roofs, sump pumps, non-paved surfaces of public or private lands.

“Sub-meter”

A privately owned water meter located downstream of the Town of Manchester Water and Sewer Department’s meter.

“Substantial Completion”

The point at which a project has been inspected and determined by the Department to be capable of providing the full benefit for which it was designed.

“Subsurface Drainage”

Water percolating from the soil into subsoil drains, through foundation walls, basement floors, underground pipes or similar sources.

“Suspended Solids”

Solid matter, measured in mg/L, which is removable by laboratory filtering procedures as set forth in the latest edition of “Standard Methods for the Examination of Water and Wastewater”,

“System Extension”

Water mains and appurtenances added to the existing water distribution system and/or sanitary sewer mains and appurtenances added to the sanitary sewer collection system.

“System Extension Agreement”

An agreement between the Department and a Developer covering the construction and reimbursement issues related to extensions of the water distribution and/or water supply system or sanitary sewer mains and appurtenances added to the sanitary sewer collection system.

“System Extension Charge”

A charge allocated to a property that benefits from a system extension, in instances where the cost of the benefit has not been assessed.

“Tap”

The process of purposely drilling into a main in order to make a connection.

“Tee/Wye”

A fitting used to connect the sanitary sewer lateral to the sanitary sewer main.

“Termination”

The discontinuance of water and/or sanitary sewer service.

“Three-family Dwelling (Triplex)”

A building containing three individual dwelling units.

“Town”

Shall mean either individually or collectively the municipalities covered by the Town of Manchester Water Service Area and the Town of Manchester Sanitary Sewer Service Area.

“Townhouse”

A dwelling unit constructed so as to have totally exposed front and rear walls for direct access to the outside light and ventilation. All vertical levels of the structure shall comprise one dwelling unit.

“Toxic Pollutant”

Any pollutant or combination of pollutants listed as toxic in regulations promulgated by the either the Environmental Protection Agency or the Department of Energy and Environmental Protection.

“Toxic Substances Control Act (TSCA)”

The Federal law that regulates the production and importation of industrial chemicals into the United States (US Code: Title 15 – Chapter 53 – Subchapter I – Section 2601 et seq.).

“Two-family Dwelling (Duplex)”

A building containing two individual dwelling units.

“User”

A person or entity that utilizes water and/or sanitary sewer service provided by the Town of Manchester Water and Sewer Department.

“Watercourse”

A natural or artificial channel that provides for the passage of water either continuously or intermittently.

“Water Distribution Main”

A water main owned, operated and, maintained by the Town of Manchester Water and Sewer Department (See Appendix - Figure #1).

“Water Distribution System”

The system consisting of water sources (i.e. reservoirs, wells, treatment facilities etc.), water distribution mains, water service pipes and appurtenances, that are owned, operated, maintained, repaired and replaced by the Town of Manchester Water and Sewer Department; located on public property, in the Town Right of Way or in an easement approved by and deeded to the Town of Manchester Water and Sewer Department for its use (See Appendix - Figure #1).

“Water Main(s)”

Water pipes used for the purpose of conveying water. This term is meant to be generic in its description and does not imply ownership (i.e. public or private) unless otherwise modified.

“Water Permit”

Document issued by the Town of Manchester Water and Sewer Department, authorizing work to be performed on the water distribution system, private fire protection systems and/or any water service pipe.

“Water Pollution Control Act (CWA)”

The Federal law that regulates discharges to the navigable waters of the United States (US Code: Title 33 – Chapter 26 – Subchapter I – Section 1251 et seq.).

“Water Pollution Control Facility (WPCF)”

An arrangement of various tanks, pumps, piping and appurtenances located at the end of the sanitary sewer collection system for the purpose of treating sewage and sludge. May also be referred to as POTW.

“Water Service”

The purveyance of public water.

“Water Service Area”

The area where the Town of Manchester Water Department has the exclusive rights to provide water to customers.

“Water Service Pipe”

The pipe from the water distribution main or other source of water to the domestic water, fire, or irrigation system

“Water Supply System”

The system consisting of the private portion of the water service pipe, domestic water system, connecting pipes, fittings, control valves and appurtenances owned, operated, maintained, repaired and replaced by the Owner of the property receiving water service (See Appendix - Figure #2).

“Water Supply Well”

A private well that is not part of the water distribution system.

“Wye”

A fitting used to connect the sanitary sewer lateral to the sanitary sewer main.

SECTION 2 – WATER DISTRIBUTION SYSTEM

2.01 OWNERSHIP AND RESPONSIBILITIES

2.01.01 MANCHESTER WATER DEPARTMENT

The Department owns, operates, maintains, repairs and replaces the water distribution system in its Water Service Area (See Appendix - Figure #1).

The Department owns, operates, maintains, repairs and replaces water service pipes from the connection at the main, up to and including the curb stop and curb box, for those pipes located on public property, in the Town Right of Way or in an easement approved by and deeded to the Town of Manchester for its use.

If the Department, during the course of its activities, determines that the Owner's water service pipe and/or any associated appurtenances are in need of maintenance, renewal, replacement or repair, the Department will notify the Owner as to the problem and shall not accept any liability for any subsequent problem or expense arising from said condition.

The Department shall determine the responsibility for the maintenance, renewal, replacement and/or repair of the water service pipe.

Only employees of the Department or contractors approved by the Department will be allowed to make connections to the water mains and/or appurtenances.

The Department shall, at its sole discretion, determine if it will renew, replace or repair any portion of the water distribution system.

The Department owns, operates, maintains, replaces and repairs the water meter, tailpieces and associated reading equipment (See Appendix - Figure #3).

The Department shall not be responsible for damages resulting from the failure of ancillary equipment, not owned by the Department, such as, but not limited to, pressure reducing valves, booster pump systems, pressure relief valves, backflow prevention devices, etc.

The Department is not responsible for the operation, maintenance, renewal, replacement or repair of any portion of the water supply system or the private fire protection system; including those portions of the water

supply system or private fire protection system that provides service under any of the following conditions:

- The private portion of a water service pipe or private fire protection system that passes through one building or dwelling unit and serves one or more buildings or dwelling units to the rear.
- The private portion of a water service pipe or private fire protection system that serves more than one building or dwelling unit.

2.01.02 OWNER

The Owner shall own, operate, maintain, repair and replace the water supply system (See Appendix - Figure #2) with the exception of the water meter. In the event of a leak not deemed by the Department to be a public safety hazard, it is the Owner's responsibility to repair the leak within thirty (30) days of its discovery. Failure to do so may result in termination of water service. If the leak is causing a public safety hazard, water service may be terminated at the discretion of the Department.

The Town and the Department have no responsibility or liability with regards to those portions of an Owner's water supply system that are deemed to be the property of the Owner, including but not limited to, any fire protection system and irrigation system, which are to be owned, operated, maintained, repaired and/or replaced by the Owner.

The Owner shall be responsible for marking out, in accordance with CBYD procedures, the portions of the water supply system, fire protection system and irrigation system that are owned, operated, maintained, repaired and replaced by the Owner (See Appendix - Figure #2, Figure #4 and Figure #5).

It is the owner's/customer's responsibility to keep their pipes and fixtures in good working order and protected from freezing.

Users shall not run water continuously. However, under emergency conditions and with the consent of the Department, water may be left running to prevent freezing of the water service pipe. The customer must pay for the water (and sewer charges if applicable) and take corrective action to address the situation.

Renewals, replacements, repairs or extensions of the water distribution system shall be made in accordance with Rules and Regulations of the Department. The Owner/Applicant shall be responsible for all associated costs.

Water and Sewer Department – Rules and Regulations

Replacement of water service pipes will be considered new construction, the cost of which shall be borne solely by the Owner, when any of the following conditions apply:

- An existing water service pipe ceases to be adequate to meet the Owner's water demands due to increased use by the Owner.
- A larger water service pipe, above the minimum standard, or the relocation of the water service pipe is requested by the Owner.
- A water service pipe is initially installed to the curb line only, and subsequently the pipe cannot be located.
- A combined service ceases to be adequate to meet the Owners water demand.

If the Department, in its sole discretion, determines that a water service pipe and/or fire service is to be discontinued, the effect of this decision is that the water service pipe/fire service is to be abandoned by the Owner at the water main. A permit from the Department is necessary to perform this work. Reconnection of water service will be considered new construction.

The Owner shall maintain unobstructed access ten (10) feet around all water service pipes, fire services and fire hydrants fronting on their property. No trees, shrubs, structures or other objects shall be located within this area. The Department is not responsible for damage to such objects resulting from the operation, maintenance, renewal, replacement or repair of its facilities.

The Owner shall be responsible for the removal of snow and/or the cutting of grass around public fire hydrants fronting on private property.

In easements deeded to the Town or the Department, the Owner shall not permit or cause any activities; permit or cause any buildings, structures or fences to be erected; plant or cause to be planted any trees, bushes, shrubs etc. which in any way interfere with the Department's rights. The Department is not responsible for damage to any such objects resulting from the operation, maintenance, renewal, replacement and/or repair of its facilities.

The Owner shall pay any and all bills rendered by the Department in accordance with the Schedule of Rates, Charges and Fees.

2.01.03 DEVELOPER

The Developer shall renew, replace, repair or extend the water distribution system and/or water supply system in accordance with these Rules and Regulations and the Town of Manchester Public Improvement Standards.

The Developer shall own, maintain, repair and replace extensions of the water distribution system and the water supply system associated with his development until such time as the maintenance/warranty period for the extensions has expired and the extensions have been accepted by the Department and turned over to the Department and/or Owner.

The procedures for acceptance, maintenance and warranty of extensions to the water distribution system and water supply systems for new subdivisions shall be as set forth in the Town of Manchester Public Improvement Standards.

If proposed water demands exceed the planned capacity of any existing water facilities (public or private), the Department may require, at the Developer's expense, construction of all improvements necessary to restore/provide adequate future capacity for the affected facilities.

2.02 WATER SERVICE

2.02.01 GENERAL

The water distribution system is designed to provide future capacity for the town-wide distribution of water. All users of the water distribution system shall pay all applicable rates, charges, and fees for its use in accordance with the Schedule of Rates, Charges and Fees.

The Department, whenever possible, will give notice in advance of work that will necessitate any interruption of water service. The Department may restrict the use of water for public health and safety reasons.

Water service by means of a water supply well on a premises shall be allowed in accordance with the applicable sections of the GSC, State regulations, Planning and Zoning Regulations and these Rules and Regulations.

2.02.02 DOMESTIC SERVICE

The method of providing water service shall be determined by the Department. The location of the water service pipe shall be approved by the Department prior to installation. The Department will require that each dwelling unit within a single-family, two-family or three-family dwelling be served by its own water service pipe and have its own water meter, providing that the structures have a townhouse configuration. In general, individual dwelling units within multi-family dwellings will not be served by separate water service pipes.

All domestic services shall be metered. Existing water service pipes from individual dwelling units shall not be combined into a single water service pipe. Combined services are not allowed.

Exception meters shall not be allowed for irrigation systems. A separate water service pipe shall be required for those systems that do not want to be charged a sewer use rate.

2.02.03 PRIVATE FIRE PROTECTION

No connection will be made to a private fire protection system for domestic purposes.

A separate fire service is required for all fire sprinkler systems, whether new or existing construction.

The Department is not responsible for the design of the private fire protection system.

The Owner, Applicant or Developer shall be responsible for ensuring that the proposed private fire protection system meets all applicable codes and shall provide evidence that the system has been approved by the responsible authorities.

All fire sprinkler systems shall have a BFD installed in accordance with the PHC.

The Department may, with permission of the Owner, operate private fire hydrants for the purpose of conducting a fire flow test. The party requesting the test shall be responsible for providing the proper gauges/connections and shall record all information pertinent to the test. The party requesting the test shall provide a report to the Department summarizing the results. The Department will provide notice of the fire flow test in a local newspaper. Fire flow tests will not be scheduled during the months of

December through March. The requesting party shall pay all fees associated with the test in accordance with the Schedule of Rates, Charges and Fees. The Department shall be held harmless for any damages caused by the operation of private fire hydrants.

The Department is not responsible for flushing, maintaining and/or the repair or replacement of private fire hydrants. The Department, in cases affecting water quality, may, at its sole discretion, assist the Owner in the flushing of private fire hydrants.

A hydrant meter, BFD and permit shall be required whenever private fire hydrants are used for non-fire uses.

2.02.04 PUBLIC FIRE PROTECTION

Public fire hydrants shall be for the purpose of fire suppression and Department operations.

The Department, in conjunction with municipal fire departments, shall determine the need for and location of public fire hydrants.

The Department will operate public fire hydrants for the purpose of conducting a fire flow test. The party requesting the test shall be responsible for providing the proper gauges/connections and shall record all information pertinent to the test. The party requesting the test shall provide a report to the Department summarizing the results. The Department will provide notice of the fire flow test in a local newspaper. Fire flow tests will not be scheduled during the months of December through March. The requesting party shall pay all fees associated with the test in accordance with the Schedule of Rates, Charges and Fees.

A hydrant meter, BFD and permit shall be required whenever public fire hydrants are used for non-fire uses.

The water distribution system is designed to provide additional capacity for fire protection. All users of the public fire protection system shall pay for its use in accordance with the Schedule of Rates, Charges and Fees.

2.02.05 WATER SUPPLY PRESSURE AND CONTINUITY

The Department does not guarantee specific or uniform pressure or an uninterrupted supply of water. Under normal operating conditions, the Department will maintain pressures within the water distribution system between 25 and 125 pounds per square inch (psi).

Water and Sewer Department – Rules and Regulations

The Department, whenever possible, will give notice in advance of work that will necessitate any interruption of the supply or change in pressure. The Department, under certain circumstances, may restrict the use of water for public health and safety reasons. The Department will not be liable for any damage resulting from the interruption of water service per Section 12-11 of the Code of Ordinances.

In cases where a customer desires pressures higher than those available, a booster pump system may, with prior approval of the Department, be installed on the domestic water system at their own expense. The Owner shall be responsible for the operation, maintenance, replacement and repair of such a system. A Limited Service Agreement shall be required for any such systems.

For new construction, where water supply pressures exceed 100 psi at the point where the water service pipe enters the building, a pressure-reducing valve (PRV) should be installed on the owner's domestic water system. The Owner shall be responsible for the operation, maintenance, repair and replacement of the PRV.

The Department may find it necessary to increase pressure in the water distribution system. When the increased pressure exceeds 100 psi at the point where the water service pipe enters the building, the Department will offer to provide a PRV to the Owner at no cost. Installation, operation, maintenance, repair and replacement of the PRV will be the Owner's responsibility. The Department agrees that in these instances all affected customers will be given written notice of the increased water pressure and the offer to supply customers with a PRV, but the Department has no responsibility or liability in connection with the installation or failure to install the PRV.

2.02.06 CROSS CONNECTION

All State regulations governing cross connections, as specified within Section 19 of the PHC, shall be strictly adhered to.

All BFDs must be approved and installed per Department and manufacturer's specifications.

All BFDs, required to be tested, shall be done so annually by the Department and are subject to the applicable fees in accordance with the Schedule of Rates, Charges and Fees.

Water and Sewer Department – Rules and Regulations

The Owner, shall in accordance with the PHC, own, operate, maintain, repair and replace all BFDs and allow the Department access to all BFDs for purposes of inspecting and testing.

The Department is not responsible for any damages due to the operation and/or testing of the BFD.

All proposed installations involving the use of BFDs shall be submitted to the Department for approval prior to installation. The submission must include mechanical drawings and a written description of the proposed use.

All BFDs must be installed so as to be readily accessible for inspection and testing while avoiding confined spaces, hazardous environments, flooding potential, freezing temperatures etc.

Reduced pressure principle backflow devices (RPDs) are prohibited from underground/vault installations.

In addition to requirements of the PHC, the Department may require additional BFDs when protection of the water distribution system is required. The following is a partial list of the situations where additional protection may be required:

- Sites with auxiliary water sources or private wells.
- Sites where toxic or objectionable materials are used.
- Sites with fire protection systems connected to a water service pipe.
- Sites with fire protection systems (on fire service only).
- Sites with irrigation systems (on pipe to irrigation's system).
- Sites where cross connection inspections may not be feasible or where a repeated history of cross connection violations has been documented.
- Temporary water service pipes.
- On water service pipes or fire hydrants used for filling operations.
- Pressure washing units.

Water and Sewer Department – Rules and Regulations

- Locations where pressures are artificially increased.

When a BFD that requires testing is installed, the customer/contractor shall notify the Department so that an initial inspection and test can be scheduled. All such BFDs are required to have permanently installed quarter-inch, flared test adapters on each test cock.

Cross connection inspections and BFD testing will be conducted during normal Department business hours. Special arrangements can be made in advance as needed and are subject to applicable fees.

If a continuous water supply is necessary during the times of BFD testing, maintenance, replacement or repair, it is the Owner's responsibility to make the necessary arrangements. Any such arrangements must be approved in advance by the Department.

All cross connection violations and/or BFD repairs/replacements shall be addressed within ninety (90) days of being identified. Failure to comply with this schedule may result in referral to the State and local health departments for further action.

Failure to comply with State of Connecticut and/or Department backflow requirements may result in termination of water service and/or fines.

SECTION 3 – SANITARY SEWER COLLECTION SYSTEM

3.01 OWNERSHIP AND RESPONSIBILITIES

3.01.01 MANCHESTER SEWER DEPARTMENT

The Department owns, operates, maintains, repairs and replaces the sanitary sewer collection system located in its Sanitary Sewer Service Area (See Appendix - Figure #6).

The Department does not maintain the wye, tee/wye, saddle or chimney portions of the sanitary sewer collection system.

If the Department, during the course of its activities, determines that the Owner's sanitary sewer main and/or any associated appurtenances are in need of maintenance, renewal, replacement or repair, the Department will notify the Owner as to the problem and shall not accept any liability for any subsequent problem or expense arising from said condition.

The Department shall determine the responsibility for maintenance, renewal, replacement or repair of any sanitary sewer main and/or sanitary sewer lateral.

Only employees of the Department or contractors approved by the Department will be allowed to make connections to sanitary sewer mains, sanitary sewer laterals and/or appurtenances.

The Department shall, at its sole discretion, determine if it will renew, replace or repair any portion of the sanitary sewer collection system.

The Department shall not be responsible for damages to personal property resulting from a sanitary sewer backup or that is caused by the failure of ancillary equipment, not owned by the Department, such as, but not limited to, grinder pumps, pump stations, pretreatment facilities, flow-equalization facilities, separators, FOG management equipment, check valves, pressure fit cleanout plugs, and below grade facilities (e.g. toilets, slop sinks, washing machines etc.).

The Department is not responsible for the operation, maintenance, renewal, replacement or repair of any sanitary sewer lateral; including sanitary sewer laterals that provide service under any of the following conditions:

- A sanitary sewer lateral that passes through one building or dwelling unit and serves one or more buildings or dwelling units to the rear.
- A sanitary sewer lateral that serves more than one building or dwelling unit.

3.01.02 OWNER

The Owner shall own, operate, maintain, replace and repair any private sanitary sewer main, sanitary sewer lateral and associated appurtenances. The Owner shall maintain the wye, tee/wye, saddle and/or chimney. In the event of a blockage, it is the Owner's responsibility to relieve and/or repair the blockage within three (3) days of its discovery. Failure to do so may result in notification of the Building Department and Health Department.

The Town and the Department have no responsibility or liability with regards to those portions of an Owner's sewage collection system that are deemed to be the property of the Owner, including but not limited to, any sanitary sewer main, sanitary sewer lateral and appurtenance, which are to be owned, operated, maintained, repaired and/or replaced by the Owner.

The Owner shall be responsible for marking out, in accordance with CBYD procedures, any private sanitary sewer main, sanitary sewer lateral and associated appurtenances that are owned, operated, maintained, repaired and replaced by the Owner.

When required by the Department, the Owner of any property ultimately discharging industrial wastes to the sanitary sewer collection system shall install a sanitary manhole on the connecting sanitary sewer main/lateral, together with such meters and other appurtenances as determined necessary by the Department, to facilitate observations, sampling and measurement of the wastes. Such structure shall be accessible, safely located and shall be constructed in accordance with plans approved by the Department (See Appendix - Figure #6).

The Owner shall, at their own expense, be responsible for the installation, operation, maintenance, replacement and repair of any ancillary equipment, not owned by the Department, such as, but not limited to, grinder pumps, pump stations, pretreatment facilities, flow-equalization facilities, separators, FOG management equipment etc.

Water and Sewer Department – Rules and Regulations

The Owner shall be responsible for ensuring that all discharges that ultimately flow to the sanitary sewer collection system conform to the parameters set forth in these Rules and Regulations.

Renewals, replacements, repairs and/or extensions of sanitary sewer mains, sanitary sewer laterals, and/or appurtenances shall be made in accordance with Rules and Regulations of the Department. The Owner/Applicant shall be responsible for all costs.

Replacement of a sanitary sewer lateral will be considered new construction, when any of the following conditions apply.

- An existing sanitary sewer lateral ceases to be adequate to meet the Owner's discharge needs due to increased use by the Owner.
- A larger sanitary sewer lateral, above the minimum standard, or the relocation of the sanitary sewer lateral is requested by the Owner.
- A sanitary sewer lateral is initially installed to the curb line only and subsequently cannot be located.

If the Department, in its sole discretion, determines that a sanitary sewer lateral or main is to be discontinued, the effect of this decision is that the lateral or main is to be abandoned by the Owner at the sanitary sewer main or manhole. A permit from the Department is necessary to perform this work. Reconnection of sanitary sewer service will be considered new construction.

In easements deeded to the Town or the Department, the Owner shall not permit or cause any activities; permit or cause any buildings, structures or fences to be erected; plant or cause to be planted any trees, bushes, shrubs etc. which in any way interfere with the exercise of the Department's rights. The Department is not responsible for damage to any such objects resulting from the operation, maintenance, renewal, replacement and/or repair of its facilities.

The Owner shall pay any and all bills issued by the Department in accordance with the Schedule of Rates, Charges and Fees.

3.01.03 DEVELOPER

The Developer shall renew, replace, repair or extend the sanitary sewer collection system in accordance with these Rules and Regulations.

The Developer shall own, maintain, repair and replace extensions of the sanitary sewer collection system associated with his development until such time as the maintenance/warranty period for the extensions has expired and the extensions have been accepted by the Department and turned over to the Department and/or Owner.

The procedures for acceptance, maintenance and warranty of extensions to the sanitary sewer collection system for new subdivisions shall be as set forth in the Town of Manchester Public Improvement Standards.

If the proposed sewage discharges exceed the planned capacity of any existing sanitary sewer facilities (public or private), the Department may require, at the Developer's expense, the construction of all improvements necessary to restore/provide adequate future capacity for the affected facilities.

3.02 SANITARY SEWER SERVICE

3.02.01 GENERAL

The sanitary sewer collection system is designed to provide future capacity for the town-wide collection of sewage. All users of the sanitary sewer collection system shall pay all applicable rates, charges, and fees for its use in accordance with the Schedule of Rates, Charges and Fees.

All water supply wells shall be metered if the premises ultimately discharge into the sanitary sewer collection system. The meter shall be installed, operated and maintained in accordance with these Rules and Regulations.

The Department can not ensure that the sanitary sewer collection system will, in all cases, be able to provide gravity and/or basement service to all properties.

The Department, whenever possible, will give notice in advance of work that will necessitate any interruption of sanitary sewer service. The Department may restrict the generation of sewage for public health and safety reasons.

All State regulations governing cross connections, as specified within Section 19 of the PHC, shall be strictly adhered to.

The Administrator shall have the right to reject the discharge of any wastes or require more stringent effluent limitations than required by the permit issued to the user under Section 22a-430 et. Seq of the GSC.

The Department, at its sole discretion, may require the documentation and implementation of a set of Best Management Practices. Said practices shall be submitted to and approved by the Department.

3.02.02 DOMESTIC WASTEWATER

The method of providing sanitary sewer service shall be determined by the Department. The location of the sanitary sewer mains, sanitary sewer laterals and appurtenances shall be approved by the Department prior to installation. The Department will require that each dwelling unit within a single-family, two-family or three-family dwelling be served by its own sanitary sewer lateral providing that the structures have a townhouse configuration. In general, individual dwelling units within multi-family dwellings will not be served by separate sanitary sewer laterals.

Existing sanitary sewer laterals from individual dwelling units shall not be combined into a single sanitary sewer lateral.

Exception meters shall not be allowed for irrigation systems. A separate water service pipe and meter shall be required for those systems that do not want to be charged a sewer use rate.

Sewer usage fees shall not be charged upon the initial filling of a swimming pool or refill due to a liner replacement provided: 1) the pool's drain is not connected to the sanitary sewer system; 2) the customer provides satisfactory documentation of the volume of water used to initially fill the pool, and/or; 3) the customer provides satisfactory documentation that the liner was replaced and the volume of water used to refill the pool.

Construction of, repairs to and/or replacement of any on-site sanitary sewage disposal system shall not be allowed if connection to the sanitary sewer collection system is available.

3.02.03 INDUSTRIAL WASTEWATER

The method of providing sanitary sewer service shall be determined by the Department. The location of the sanitary sewer mains, sanitary sewer laterals, sanitary manholes for inspection, and appurtenances shall be approved by the Department prior to installation (See Appendix - Figure #6). The Department will require that each building be served by its own sanitary sewer lateral.

Existing sanitary sewer laterals from individual buildings shall not be combined into a single sanitary sewer lateral.

Exception meters shall not be allowed for irrigation systems. A separate water service pipe and meter shall be required for those systems that do not want to be charged a sewer use rate.

Construction of, repairs to and/or replacement of any on-site sanitary sewage disposal system shall not be allowed if connection to the sanitary sewer collection system is available.

3.02.04 DISCHARGE REQUIREMENTS

Each user shall provide facilities necessary for the prevention of the discharge of any prohibited/hazardous materials or substances regulated by these Rules and Regulations. Such facilities shall be installed, owned, operated, maintained, repaired and replaced by the Owner, at the Owner's own cost and expense. The Commissioner or the Department may require that plans showing the facilities and operating procedures be submitted for review and approval prior to construction of the facilities.

All new and existing food preparation establishments that generate and discharge fats, oils and grease in their wastewater flow shall install, own, operate, maintain, repair and replace FOG management equipment in accordance with the requirements set forth in the DEEP "General Permit for the Discharge of Wastewater Associated with Food Preparation Establishments".

No user shall increase the use of process water in an attempt to dilute a discharge as a partial or complete substitute for adequate treatment to achieve compliance with the limitations contained in the Federal Categorical Pretreatment Standards, these Rules and Regulations, and/or any specific pollutant limitation which may be developed.

All users, ultimately discharging into the sanitary sewer collection system, shall perform such monitoring of the discharge as required by the Commissioner in any discharge permit issued pursuant to Section 22a-430 et. seq. of the GSC. Any reports and/or records required under Sections 22a-430 or 22a-430(b) of the GSC shall be submitted to the Department.

All measurements, tests and analyses of the characteristics of sewage to which reference is made in these Rules and Regulations shall be determined in accordance with the approved methods contained in Title

40 CFR Part 136. Sampling methods, locations, times, durations and frequencies are to be determined on an individual basis subject to the stipulations and general conditions of the discharger's permit issued under Section 22a-430(b) of the GSC. The sample shall be collected at a point along the industrial waste stream where a representative sample of the industrial wastewater may be obtained prior to its being diluted by domestic sewage in the sanitary sewer lateral. The sampling site shall be installed, owned, maintained, repaired and replaced by the Owner, at the Owner's expense.

A notice shall be permanently posted on the user's bulletin board or other prominent place advising employees whom to call in the event of a non-compliant discharge. In the event of such a discharge, the Department shall be notified immediately. Employers shall ensure that all employees are advised of the emergency notification procedure.

Within five (5) days following an accidental discharge, the user shall submit to the Department a detailed written report describing the cause of the discharge and the measures to be taken by the user to prevent similar future occurrences. Such notification shall not relieve the user of any expense, loss, damage or other liability which may be incurred as a result of damage to the sanitary sewer collection system, WPCF, the environment or any other damage to persons or property. Such notification shall not relieve the user of any fines, civil penalties or other liabilities which may be imposed under these Rules and Regulations or any other applicable law.

The Department recognizes that from time to time there may be extraordinary circumstances where the Rules and Regulations may need to be modified to address the requirements of a specific discharger. Any such modification must always be in writing and signed by authorized representatives of the Department and the discharger prior to the discharge. However, any such agreement must not contravene any requirements of existing Federal, State and/or local regulations and must be compatible with any user charge and industrial cost recovery system in effect.

3.02.05 DISCHARGE LIMITS

No person shall discharge or cause to be discharged any unpolluted waters such as stormwater surface runoff, groundwater or subsurface drainage to any sanitary sewer.

Stormwater surface runoff, groundwater and all other unpolluted discharges emanating from roof downspouts, foundation drains, sump

Water and Sewer Department – Rules and Regulations

pumps, areaway drains, yard drains etc. shall be discharged to drainage systems that are specifically designated as storm sewers which discharge to a watercourse in accordance with all applicable Federal and State laws and regulations.

No septage shall be discharged to the sanitary sewer collection system.

No user shall discharge or cause to be discharged, directly or indirectly, any pollutant or wastewater which will interfere with the operation or performance of the sanitary sewer collection system and/or the WPCF. These general prohibitions apply to all such users of the sanitary sewer collection system and the WPCF, whether or not the user is subject to any other Federal or State pretreatment standards or requirements. No user shall discharge the following substances to the sanitary sewer collection system:

- Any noxious or malodorous liquids, solids, gases or vapors which, by reason of their nature, quantity or interaction with sewage are or may be sufficient, either alone or by interaction with other substances, to cause fire or explosion or to be injurious in any other way to the WPCF or to the operation of the WPCF.
- Any solids or viscous substances which may cause obstruction to the flow in a sewer or other interference with the operation of the WPCF, including substances such as but not limited to fats, oils and grease, garbage with particles greater than one-half (1/2) inch in any dimension, by-products from animal rendering facilities, ashes, cinders, sand, metal, glass, wood shavings, rags, diapers, spent grains, spent hops, wastepaper, wood, paint, plastics, gas, volatile solvents, tar, asphalt residues, residues from refining or processing of fuel or lubricating oil, mud, glass grinding or polishing wastes.
- Any sewage with a FOG concentration in excess of one hundred (100) milligrams per liter, as determined by the currently approved test for total recoverable fats, oils and grease listed in Title 40 CFR 136 or in concentrations which, as determined by the Department, will harm the sanitary sewer collection system and/or the WPCF.
- Any renderable FOG.
- Any sewage having a pH lower than 6.0, higher than 9.5 or having any other corrosive property capable of causing damage or hazard to the structures and equipment of the sanitary sewer collection system and/or the WPCF or to Town personnel. The limits of pH

Water and Sewer Department – Rules and Regulations

for any industrial wastewater discharge shall be established under applicable discharge permits.

- Any sewage containing toxic pollutants in sufficient quantity, either singly or by interacting with other pollutants, that may exceed the limitation set forth in a categorical pretreatment standard, injure or interfere with any wastewater treatment process, constitute a hazard to humans, animals or plant life, or create a toxic effect from the discharge of the WPCF. A toxic pollutant shall include but not be limited to any pollutant identified pursuant to the Clean Water Act.
- Any sewage which, by interaction with other sewage in the public sewer, releases obnoxious gases, forms suspended solids which interfere with the sanitary sewer collection system, creates a condition which may be deleterious to structures and treatment processes or which may cause the effluent limitations of the WPCF's NPDES permit to be exceeded.
- Any substance which, when discharged to the sanitary sewer collection system, causes the WPCF to be in non-compliance with Federal or State sludge use or disposal criteria, guidelines or regulations applicable to the sludge management method being used.
- Any sewage containing substances which are not amenable to treatment or reduction by the wastewater treatment process employed or which are amenable to treatment only to such degree that the WPCF effluent cannot meet the limits stipulated in the Town of Manchester's NPDES permit.
- Any sewage having a temperature higher than 150°F (66°C).
- Any sewage containing fat, wax, grease, petroleum or mineral oil.
- Any radioactive wastes or isotopes of such half-life or concentration as may exceed limits established by the Commissioner in compliance with all applicable Federal and State regulations.
- Any material which exerts or causes:
 1. Unusual concentrations of inert suspended solids.
 2. Excessive discoloration.

3. Unusual biochemical oxygen demand, chemical oxygen demand or disinfection demand in such quantities as to constitute a significant load on the WPCF.
 4. Unusual volume of flow or concentrations of wastes constituting a slug.
- Any overflow or release of wastes of high concentration from holding tanks.
 - Any sewage with a concentration of pollutants in excess of any existing Federal, State or local discharge permit or which may cause the WPCF to violate its NPDES Permit.

Upon the promulgation of Federal Categorical Pretreatment Standards for a particular industrial subcategory, the Federal standard, if more stringent than the limitations imposed under these Rules and Regulations for sources in the subcategory, shall supersede the limitations imposed herein.

3.02.06 REJECTION AND/OR PRETREATMENT OF WASTE

Any sewage ultimately discharged to the sanitary sewer collection system which contains the substances or possesses the characteristics listed in Paragraph 3.02.05 or referenced within these Rules and Regulations and which, in the judgment of the Commissioner, may have deleterious effects upon the WPCF, pump stations and associated equipment or receiving waters or which otherwise may create a hazard to life or constitute a public nuisance, the Commissioner may, in accordance with Section 22a-430 et. seq. of the Connecticut General Statutes, take the following actions:

- Reject the discharge of the waste.
- Require pretreatment to an acceptable condition for discharge to a sanitary sewer main.
- Require control over the quantities and rates of discharge.

If the Commissioner permits the pretreatment or equalization of waste flows, the design and installation of the equipment shall be subject to the review and approval of the Commissioner and the Department in accordance with the requirements of all applicable codes, ordinances and laws.

SECTION 4 – CUSTOMER SERVICE

4.01 BILLING

4.01.01 GENERAL

All water registered by a meter and all other Departmental billings shall be invoiced in accordance with the Schedule of Rates, Charges and Fees.

All water registered by a meter, other than that registered through an exception meter for industrial/commercial processes or an irrigation meter as defined herein, shall be invoiced for sewer use.

Some services, including certain services provided during normal working hours, after normal working hours and/or on weekends or holidays may be subject to a charge. The Department agrees to provide customers adequate notice when there is a charge associated with a service.

Bills for chargeable work or repairs shall be rendered upon completion of the work. Anyone requesting the Department to perform such work may be required to enter into a payment agreement and make a deposit in advance based upon the estimated cost of the work.

Bills are due and payable upon receipt. Bills not paid within thirty (30) days of the billing date shall be considered delinquent. Delinquent bills shall be subject to interest at the rate and in the manner provided by the GSC for delinquent taxes.

Bills not paid when due shall constitute an automatic lien on the property served and a charge against the Owner. Such liens may be recorded, continued and/or released in a manner provided by the GSC governing such liens. Such liens shall take precedence over all other liens and encumbrances except taxes and may be enforced in the same manner as property tax liens. The customer shall pay all costs associated with the filing of the lien in accordance with the applicable State statutes.

Failure to pay bills when due may, at the sole discretion of the Department, result in the revocation of any permits associated with the work and/or service for which the bill was generated (e.g. water and sewer permit, septage discharge permit, etc.).

Delinquent accounts will be processed in accordance with Town and Department policy.

Water and Sewer Department – Rules and Regulations

In cases where a meter fails to register, the meter will be replaced or repaired by the Department. The customer will be charged the average daily consumption as recorded for a similar period.

In cases where the purveyance of water is found to be unmetered, the customer may be back-billed for water and/or sanitary sewer service from the time the Department determines that it is likely the unmetered water usage began until such time as a meter is installed. The billing for such unmetered usage will be in accordance with Schedule of Rates, Charges and Fees.

Individual bills may not be combined into one bill.

The Department will directly bill the Owner of the property. In the case where the Owner and Tenant agree, then the Tenant (single occupancy only) will be billed directly, an Owner/Tenant Billing Authorization Form must be executed. Failure of the tenant to pay the bill when due does not relieve the Owner of responsibility for said payment.

4.01.02 ADJUSTMENT OF BILLS

Bills that are incorrect due to meter or billing errors will be adjusted in accordance with the applicable provision of PURA Regulations (Section 16-11-71) for the following items:

- Meter over/under registration.
- No meter registration.
- Incorrect reading/calculation.

Billing complaints and/or disputed bills will be handled in accordance with Departmental procedures and the applicable provisions of PURA Regulations (Section 16-11-77 and Section 16-3-100).

4.02 TERMINATION OF SERVICE

The Department will utilize the applicable provision of the PURA Regulations (Section 16-3-100) for termination of water and/or sanitary sewer service. These include, but are not limited to the following:

The Department may refuse or discontinue water and/or sanitary sewer service without notice in the event of:

Water and Sewer Department – Rules and Regulations

- A condition that creates a public health and safety hazard as determined by the Department.

The Department may refuse or discontinue water and/or sanitary sewer service with notice in the event of:

- Tampering with water service pipes, fire services, sanitary sewer laterals/mains or meters.
- Fraud or material misrepresentation in obtaining water and/or sanitary sewer service.
- Customer use of equipment in such a manner as to adversely affect the Department's equipment or water/sanitary sewer service to others after the customer has been given an opportunity to correct the situation.
- Failure of the customer to allow the Department reasonable and unobstructed access to its equipment.
- Failure by the customer to furnish or subsequent withdrawal of any equipment, permits, certificates, easements, rights of way or other documents which have been specified by the Department as a condition for obtaining water and/or sanitary sewer service.
- Failure by the customer to comply with the applicable provisions of the Department's collection and payment policies.
- Unauthorized use.
- Furnishing water and/or sanitary sewer service contrary to any orders, ordinances or laws of the Federal, State or local governments.
- Non-compliance with these Rules and Regulations.
- Any discharge in violation of these Rules and Regulations.

4.03 METERS AND METER TESTING

The Department will own, install, maintain, replace and repair all of its meters. The Department shall determine the type, size and location of the

Water and Sewer Department – Rules and Regulations

meter to be installed. Each meter will have a separate and distinct water service pipe.

The Department will conduct periodic meter testing in accordance with test procedures contained in the AWWA Standards for Water Meters and/or AWWA Manual M6 “Water Meters – Selection, Installation, Testing, and Maintenance”. In accordance with Section 16-11-89 of the PURA regulations, a customer may request that a meter be tested.

Meters are set and sealed by the Department. No one shall break a seal, disconnect, open, adjust or tamper with any meter.

The Owner, at the sole discretion of the Department, shall pay for repairs to or replacement of any meter that has damage above and beyond that associated with normal wear and tear (i.e. freezing, fire etc.).

The Owner shall provide an accessible and protected location for the meter. The location is subject to the approval of the Department and shall be installed in accordance with the following criteria.

- The meter setting shall, whenever possible, be located inside a building, protected from freezing and shall be located at the point where the water service pipe or water supply well pipe enters the building.
- The location of all meter settings must be readily accessible for installation, reading, maintenance, replacement, inspection and testing.
- If the Department finds that alterations, obstructions or other modifications have been made that affect the accessibility to the meter settings, the Owner may be required to correct the situation at his sole expense.
- At the sole discretion of the Department, meter settings may be located in meter pits. Such meter pit will be constructed and installed in accordance with Department specifications and at the Owner’s expense. Such meter pits will be owned, maintained, repaired and replaced by the Owner.
- Bypasses of the meter settings shall not be allowed.
- The Owner is responsible for operating, maintaining, replacing and repairing the valves associated with the meter setting and is

Water and Sewer Department – Rules and Regulations

responsible for any repairs necessary to comply with these requirements (See Appendix - Figure #3).

The Department will not install sub-meters. Property Owners may install and read sub-meters. The Owners are responsible for the operation, maintenance, replacement and repair of said sub-meters. Bills will be invoiced based upon the Department's meter(s) only.

SECTION 5 – PERMITS AND PROGRAMS

5.01 GENERAL

Each permittee shall hold harmless the Town of Manchester, its agents and servants from all losses, claims for loss, damages or injuries arising from the operations conducted by such permittee, their employees or agents in association with any permit issued by the Town. Such exclusions shall include any negligence or failure of the permittee, his employees or agents to conduct their operations in such a manner so as to guard or protect from damage, obstruction or disturbance, any highway, pavement, sidewalk, signage, trees, landscaping, property (public or private).

Any requests for a waiver of the Department's rates, charges or fees, must be submitted in writing to the Department for approval by the General Manager or his designated agent.

5.02 WATER AND SEWER PERMIT

Any individual making connection to, renewal of, replacement of, repairs to, extension of or termination of any portion of the water distribution system, private fire protection system, private water mains, any water service pipe, the sanitary sewer collection system, sanitary sewer main and/or any sanitary sewer lateral shall obtain a water permit and/or sanitary sewer permit prior to commencing the work.

The Owner, or his/her designated agent, shall apply for a permit at the Engineering Maps and Records Unit located at 494 Main Street, Manchester, Connecticut.

The Department will review all applications for accuracy and completeness within five (5) business days of receipt. If an application is deficient, the Applicant will be notified of the deficiencies and shall have seven (7) business days from the date of notification to provide the additional information. At the end of the seven (7) day period, if the application is still deficient, it will be rejected.

All information submitted as part of an application shall be considered accurate and binding upon the Applicant. Any falsification of said information shall be grounds for rejection of the application and/or revocation of the permit. Any deviation from the permit, without prior

Water and Sewer Department – Rules and Regulations

approval of the Department, shall also be grounds for revocation of the permit.

All permit applications submitted to the Department shall include the following documents:

1. Application Form – Complete all pertinent sections.
2. Approved Engineering Plan/Profile (2 copies) – The engineering plan shall be prepared and stamped by a professional engineer licensed in the State of Connecticut. The plan shall be at a scale of 1"=40' and shall include, but not be limited to all roadways, storm drainage, sanitary sewer mains, sanitary sewer laterals, water mains, water service pipes, retaining walls, structures and other proposed construction, both on-site and off-site, necessary to serve the property.

OR

Approved Site Plan (2 Copies) – The site plan may only be used for single family, two family or three family dwellings on a single lot connecting to existing water/sewer facilities. The plan shall be at a scale of 1"=40' and shall include, but not be limited to, proposed type and location of buildings, structures, driveways, landscaping, water and sanitary sewer services, etc.

3. Other Permits, Approvals or Licenses. – Nothing in these regulations shall supercede any requirement for an Applicant to obtain any other approvals, permits or licenses required by law or regulation of the Federal, State and local governments, including any approval required by the Connecticut Department of Energy and Environmental Protection and the U.S. Army Corps of Engineers. Obtaining such approvals, permits or licenses is the sole responsibility of the Applicant. Copies of other approvals, permits or licenses required in order to perform the work, shall be included with the application. Such items may include, but not be limited to the following:
 - Development Plans approved and stamped by the Planning and Zoning Commission.
 - Town of Manchester – Right of Way Encroachment Permit.
 - State DOT Encroachment Permit.

Water and Sewer Department – Rules and Regulations

- Eighth District Sewer Permit.
- Call-Before-You-Dig number.
- DEEP General or Individual Permits.
- Federal, State or local wetland permits.
- Blasting Permit.
- Easement and/or agreement documents specific to the work being performed.
- Contractor's Licenses

In cases where work is being done in areas that are normally regulated by another agency, but the nature of the work is such that a permit is not required, a letter from the cognizant authority of that agency indicating that no permit is required shall accompany the application.

Unless specified otherwise, all charges, fees and assessments for all work covered by the application shall be paid, in full, by check, or other approved method prior to issuance of the permit. In addition, the Owner and his contractor performing the work shall pay in full, any delinquent bills, prior to issuance of the permit. When a phasing plan has been approved by the Planning and Zoning Commission, charges and fees may be paid in accordance with the approved plan. An application shall be considered approved only after the Department has assigned a permit number to the application.

If an Applicant's check does not clear the bank, the Applicant shall have seven (7) days to present a certified bank check to the Department covering all fees including a returned check fee as provided for in the Schedule of Rates, Charges and Fees. Failure to do so shall result in revocation of the permit.

Once a permit has been issued, the work covered by that permit must commence within a one (1) year period or the permit will be revoked.

If a permit is revoked, a new application must be submitted for approval and a new application fee paid. The new permit shall be subject to the Schedule of Rates, Charges and Fees and the Department's procedures in effect at the time of the new application. If there have been any changes in the rates, charges and/or fees associated with the permit, only

the incremental increases above and beyond any previously paid rate, charges and/or fees will be required to be paid.

Where a water and/or sanitary sewer permit is required, no building permit shall be granted until the water and/or sanitary sewer permit has been issued. This requirement is intended to ensure that no construction (i.e. grading, excavation, footing, foundation, superstructure, etc.) commences until the water and/or sanitary sewer permit has been issued.

In the event that a water and/or sanitary sewer permit has been revoked, the permittee will be notified in writing and the Department will request the Chief Building Official to issue a stop work order for all work associated with the building permit.

5.03 DISCHARGE PERMIT

In accordance with Section 22a-430 et. seq. of the GCS, a permit from the Commissioner is required prior to the initiation of discharge of any of the following wastewaters to the sanitary sewer collection system:

- Industrial wastewater of any quantity.
- Domestic sewage in excess of fifty thousand (50,000) gallons per day to the WPCF.

A potential discharger must submit a permit application to and in accordance with the procedures set forth by the Department of Energy and Environmental Protection. Copies of all such applications and the final approved permit shall be forwarded to the Town.

5.04 FATS, OILS, AND GREASE (FOG) PERMIT

In accordance with Section 22a-430(b) of the GCS, all Class III and IV food preparation establishments as defined by Section 19-13-B42 of the State of Connecticut Public Health Code or any other facility discharging FOG above the effluent limits in Section 5(c)(2) as defined by DEEP General Permit conditions shall obtain a FOG permit prior to discharging, directly or indirectly, to the sanitary sewer collection system. All necessary design, specifications and support documentation, as determined by the Department, shall accompany the permit application.

Water and Sewer Department – Rules and Regulations

The Owner, his/her designated contact person or the lessee shall apply for a permit at the Engineering Maps and Records Unit located at 494 Main Street, Manchester, Connecticut.

The Department will review all applications for accuracy and completeness within ten (10) business days of receipt. If an application is deficient, the Applicant will be notified of the deficiencies and shall have ten (10) business days from the date of notification to provide the additional information. At the end of the ten (10) day period, if the application is still deficient, it will be rejected.

All information submitted as part of an application shall be considered accurate and binding upon the Applicant. Any falsification of said information shall be grounds for rejection of the application and/or revocation of the permit. Any deviation from the permit, without prior approval of the Department, shall also be grounds for revocation of the permit.

All permit applications submitted to the Department shall include the following documents.

1. Application Form – Complete all pertinent sections.
2. Calculations – Flow/sizing calculations necessary to determine the size of the separator.

5.05 SEPTAGE DISCHARGE PERMIT

All septage haulers proposing to discharge at the WPCF shall register with the Town of Manchester Landfill Facility.

Unless specified otherwise, all charges covered by this permit shall be paid in full, by check or other approved method, upon invoicing by the Department. In addition, the applicant shall, prior to issuance of the permit, pay in full, any delinquent bills.

Only septage collected within the limits of the Town of Manchester may be discharged at the WPCF.

Hours of operation for discharge of septage to the WPCF shall be the same as the hours of operation for the Town of Manchester Landfill.

Any unauthorized discharge of septage to the sanitary sewer collection system shall result in the revocation of discharge privileges and be subject to prosecution under the law.

5.06 HYDRANT METER PERMIT

Where no water supply system exists, the Department may, at its sole discretion, allow the temporary use of water from fire hydrants for the following:

- Construction related activities
- Special events
- Agricultural

Applications must be made to the Department prior to use. Such use will be charged in accordance with the Department's Schedule of Rates, Charges and Fees.

Unless specified otherwise, all charges covered by this permit shall be paid in full, by check or other approved method, upon invoicing by the Department. In addition, the applicant shall, prior to issuance of the permit, pay in full, any delinquent bills.

All water use must be metered. Failure to comply shall result in the revocation of the permit.

Permits must be present on the site and available upon request.

Hydrant meter use will be restricted to the period from April 1st to November 30th.

5.07 PASSIVE RECREATION PROGRAM

5.07.01 GENERAL

Manchester Water Department customers, town residents, property/business owners and Town employees are allowed access on specified trails through the Department's watershed property under the Passive Recreation Program. The program is authorized under GSC 25-

Water and Sewer Department – Rules and Regulations

43c and governed by a Recreational Activity Permit issued by the Connecticut Department of Public Health.

Participants must provide proof that they are at least eighteen (18) years of age. No minor children shall be permitted on Department land unless accompanied by a parent or guardian who is eligible under the program.

Participants must have proof of eligibility at all times while on Department land. The participant shall, upon request of any employee or agent of the Town, display such proof for inspection.

The passive recreation program is only available for use during the hours between sunrise and sunset.

5.07.02 RESPONSIBILITIES

The use of the Department's land shall be at the sole risk of the Participant.

The Participant agrees to remain on designated trails and abide by all Rules and Regulations posted on the Department's land, specified in the Recreational Activity Program, or contained herein.

Activities such as, but not limited to, hunting, trapping, fishing, swimming, boating, camping, cooking, lighting fires, ice skating, carrying or discharging firearms and the operation of motor vehicles or snowmobiles within the Department's land is prohibited.

Throwing, depositing or leaving any litter, leaves, refuse, trash or garbage on Department land is prohibited.

The exercising of or entry of domestic or farm animals on Department land is prohibited. Dogs must be under control and are not allowed in the reservoir, tributaries or on dam faces.

No activity will be allowed within any area of the Department's land which has been closed for the purpose of conducting forest, dam, spillway and/or trail/accessway maintenance operations.

5.07.03 GROUP AND SPECIAL EVENT PERMITS

Group and/or special event permits are required for civic, fraternal, members of recognized emergency response organizations and charitable

or community service groups organized within the Department's Water Service Area or recognized emergency response organizations. Liability insurance, traffic control, parking or transportation arrangements, sanitary facilities, litter control, first aid availability may be required by the Town. These requirements will be determined by the Department based on the size and nature of the group activity.

Such permits shall be issued for a specific day(s) or duration.

Group or special event permits shall be issued in the name of the group and to a specific individual who shall assume the responsibility for and be authorized to act on behalf of the group.

5.07.04 VIOLATIONS

Violation of any Federal or State statute, Town ordinance, or these Rules and Regulations relative to activity at a reservoir, within a watershed or on any Department land shall be punishable in accordance with applicable law.

Any alteration, defacement or falsification of a group permit or proof of eligibility shall result in immediate revocation of privileges.

5.08 CORDWOOD PERMIT

The Department may, from time to time, designate certain areas of Department land for the cutting and removal of cordwood. Prior to the cutting or removal of cordwood a permit must be obtained.

Application for cordwood permits shall be made at the Department's office located at 125 Spring Street, Manchester, Connecticut.

Permits will be issued at the General Services office located at 494 Main Street, Manchester, Connecticut upon approval of the application and payment of the required fee.

SECTION 6 – SYSTEM EXTENSIONS

6.01 GENERAL

All system extensions shall be performed in accordance with the requirements set forth in these Rules and Regulations and the Town of Manchester Public Improvement Standards.

Extensions to the water distribution system and/or the sanitary sewer collection system shall be located on public property, within a Town Right of Way or within an easement approved by and deeded to the Town of Manchester for its use. The Department shall have the right to connect to any system extension without any charge to the Town.

The Department will have final approval over system extension criteria such as, but not limited to, length of extension, main size, material, location of appurtenances and routing. System extensions shall be in accordance with the Department's Individual Water Supply Plan, Water Quality Improvement Plan, Facilities Plan for Wastewater Collection and Treatment Works and any other infrastructure improvements plans (collectively referred to as the Plans), and the Town of Manchester Public Improvement Standards. Any departure from the Plans, as determined by the Department, will require the Applicant/Developer to conduct an engineering study at his or her own expense. The scope and content of the study shall be submitted to and approved by the Department prior to commencement of the study.

The Developer shall bear all costs for the design and installation of any system extension within the Department's Water and/or Sanitary Sewer Service Areas when such extensions are initiated by the Developer.

The Developer shall be responsible for all rates, charges and fees associated with any system extension.

System extensions that conform to the Plans, which are approved by the Planning and Zoning Commission for subdivision or other development, and where all costs are borne exclusively by the Developer, shall be reviewed and approved by the Department.

System extensions initiated by the Department, which improve the overall water distribution system and/or sanitary sewer collection system, or are carried out in order to accomplish the intent of the plans shall be the sole responsibility of the Department. All costs shall be borne by the Department and may be subject to charges or assessments assigned in

accordance with the Department's Rules and Regulations and other Town ordinances and policies.

System extensions may be carried out in a partnership between the Developer and the Department at the sole discretion of the Department. The Department shall consider a partnership arrangement for a system extension when it is determined by the Department that there is a compelling interest for the extension to occur, that such an extension is determined to be beyond that required for a particular development, that the extension cannot be reasonably or cost effectively connected to the existing infrastructure by the Developer, and that the extension would provide a distinct benefit to the Department. System extensions requiring a partnership arrangement between the Developer and the Department, either through materials, in-kind services or through some form of financial contribution to the project, must be subject to a System Extension Agreement.

6.02 SYSTEM EXTENSION AGREEMENT

All System Extension Agreements must be in writing and approved by the General Manager and/or Board of Directors as provided herein. All requests for System Extension Agreements shall be submitted in writing to the Department, and will only be accepted from the Owner or his designated representative. The following items shall be submitted as part of the application for a System Extension Agreement:

- Approved plans as specified in Section 5.02.
- Preliminary estimate of the system extension costs based upon the approved plans and in a form approved by the Department.
- Evidence that the Applicant has obtained all permits or approvals required to complete the work associated with the agreement.

The application will be reviewed by the Department for accuracy and completeness within thirty (30) days of submission. The Department may require additional submittals. If an application is deficient, the Applicant will be notified of the deficiencies and shall have fifteen (15) days from the date of notification to provide the additional information. At the end of the fifteen (15) day period, if the application is still deficient, it will be rejected.

The Department will not seek the necessary approvals from the General Manager or the Board of Directors for the System Extension Agreement until all required information has been submitted.

System Extension Agreements shall be executed by the Applicant within thirty (30) days of approval by the Board or General Manager. No permit will be issued for work covered by a System Extension Agreement until said agreement is approved and fully executed.

6.03 REIMBURSEMENT OF SYSTEM EXTENSION COSTS

6.03.01 GENERAL

When a System Extension Agreement includes provisions for the reimbursement of costs to the Developer through charges and/or assessments levied and collected by the Town of Manchester, direct subsidy payments by the Department, the provision of materials and/or in-kind services, or the waiver of fees; the terms of such reimbursements shall be set forth in the System Extension Agreement.

When the Department has funds allocated for system extensions, has available material, is providing in-kind services, and/or waiving fees, the System Extension Agreement shall be submitted to the General Manager for approval and execution. If assessments are to be levied or an appropriation of funds is required, the System Extension Agreement must be approved by the Board of Directors before it can be executed by the General Manager.

System extension costs eligible for reimbursement may, at the discretion of the Department, include survey, engineering, design, material, equipment and labor, including the prevailing wage rates for overhead.

All requests for reimbursement under a System Extension Agreement shall be accompanied by an affidavit submitted by the Developer to the Department certifying said costs. Under no circumstances, shall the value of any reimbursement, regardless of method, exceed the costs of the system extension. The affidavit shall be in a form acceptable to the Department and include, but not be limited to material invoices, certified payrolls, list of equipment, and invoices for sub-contractor services.

Reimbursements under a System Extension Agreement are limited to a period of ten (10) years from the date that the Department issues the Certificate of Substantial Completion for the work covered by the agreement.

6.03.02 DIRECT PAYMENT

The Department will make direct payments for eligible reimbursement costs as set forth and in accordance with the provisions of the System Extension Agreement.

The Department, at its sole discretion, may recommend for the approval of the General Manager, the waiver, in whole or in part of permit fees, inspection fees or connection charges. These fees or charges will be as defined in the Department's Schedule of Rates, Charges and Fees.

6.03.03 MATERIALS OR IN-KIND SERVICES

The Department may, at its sole discretion, provide all or a portion of the materials required to perform the system extension. Such materials will not be eligible for any other form of reimbursement.

The Department may at its sole discretion, provide engineering or inspection services or provide labor and equipment towards the actual construction of the system extension.

6.03.04 ASSESSMENTS

Assessments will be performed in accordance with the procedures set forth in Section 6.04.01 of these Rules and Regulations. Reimbursements due to a Developer from such assessments will be reimbursed as provided in the System Extension Agreement.

6.04 LEVYING OF ASSESSMENTS

6.04.01 PROCEDURES

Prior to the initiation of any project involving the levying of assessments an informational meeting will be held with all property owners affected by the project.

Once the informational meeting has been held, a public hearing will be conducted before the Board of Directors to determine the feasibility of the system extension. Benefiting property owners shall be notified of the public hearing by certified mail/return receipt requested not later than fifteen (15) days prior to the date of the hearing.

Upon approval of the project feasibility by the Board of Directors, a caveat will be placed on the land records notifying all benefiting property owners

Water and Sewer Department – Rules and Regulations

of the intention of the Department to proceed with the project and to subsequently levy assessments.

When the system extension has been completed and the Department has certified the costs, the preliminary assessment against benefiting properties will be determined by the Department utilizing the methods contained in these Rules and Regulations. An informational meeting will be conducted for those property owners who are to be assessed. The property owners will receive a letter stating the time, date and location of the meeting.

Final assessments will not be levied until a public hearing is conducted before the Board of Directors at which time the benefiting property owners will have the opportunity to be heard. Benefiting property owners shall be notified of the time and place of the public hearing by certified mail/return receipt requested not later fifteen (15) days prior to the date of the public hearing. After the public hearing, the Board of Directors shall establish the amount of the final assessments and a payment method as defined in these Rules and Regulations. Notice of the final assessment and payment method will be mailed to the property owners affected by said assessment prior to placement of a lien against the properties.

Notice of the payment method and due date will be published at least twice within a period of fifteen (15) days in a newspaper having a general circulation in the municipality. A copy of such notice will be sent to the Owner of the assessed property at the last known address. Assessments shall be due and payable no earlier than thirty (30) days after the first publication of such notice. After such notice, a caveat shall be placed on the land records. In addition to the caveat, assessments levied by the installment method shall have a certificate of installment recorded in the land record.

Any assessment or installment not paid within thirty (30) days after the due date shall be delinquent and subject to interest from the due date at the interest rate and in the manner provided by the GSC for delinquent property taxes. Whenever any installment of an assessment becomes delinquent, the interest on such delinquent installment shall be as stated above or five (5) dollars, whichever is greater.

Any unpaid assessment or installment and any interest due thereon shall constitute a lien upon the property. Such liens may be continued, recorded or released in a manner provided by the GSC governing such liens. Such liens shall take precedence over all other liens and encumbrances except taxes and may be enforced in the same manner as

property tax liens. The customer shall pay all costs associated with the filing of the lien in accordance with the applicable GSC.

6.04.02 METHODOLOGY

The Department, at its sole discretion, will determine which of the following methodologies most accurately reflects the appropriate allocation of the costs associated with the system extension.

- a) The unit cost will be determined by taking the total cost of the extension and dividing it by the sum of the front footage of all benefiting properties, including the property requiring the extension. The unit cost will be multiplied by the front footage of each of the benefiting properties to determine the assessment.
- b) The unit cost will be determined by taking the total cost of the extension and dividing it by the sum of acres of all benefiting properties, including the property requiring the extension. This unit cost will be multiplied by the acreage of each of the benefiting properties to determine the assessment.
- c) A combination of method a or b.

Only the benefit of an 8-inch water distribution main and/or sanitary sewer main shall be assessed against the benefiting properties.

In general, the assessment levied for a property should not exceed the special benefit accruing to the property.

6.04.03 PAYMENT OPTIONS

In conjunction with levying the final assessment against benefiting properties, the Board of Directors shall also approve the method for payment of the assessment. The payment method will consist of the following options:

- Payment of the assessment will be due, in full, after the date the final assessment is levied by the Board of Directors and properly noticed.
- Payment of the assessment will be deferred until such time as the benefiting property wishes to connect the property to the system extension and makes application to do so. Payment of the assessment will be due in full at the time of issuance of the permit.

- Payment of the assessment may be made in equal annual installments for a period not greater than fifteen (15) years as determined by the Board of Directors. Interest may be included for those system extensions that are funded by the Department. If at any time during the period of such installments, the benefiting property or any portion thereof connects to said extension, payment of the remainder of the balance of the assessment will be immediately due and payable, in full, under the following conditions:
 - The benefiting property is zoned for commercial or business use.
 - The benefiting property is zoned for industrial use.
 - The benefiting property is zoned for residential use and has been approved for development as a subdivision.

Elderly or disabled property owners who currently have an installment payment plan and are eligible for tax relief under State statute may apply to the Town of Manchester for approval of an alternate payment plan. Such payment plan shall allow for payment of only the annual interest charge. The outstanding principal balance will be deferred until the transfer of title on the assessed property or upon the death of the eligible property owner. Any such payment plan shall be approved by the Board of Directors and shall be subject to annual review.

6.05 SYSTEM EXTENSION CHARGE

In cases where the water distribution system and/or the sanitary sewer collection system is extended, the cost is borne solely by the Department and the costs are not formally assessed against benefiting properties, any property connecting to such a system extension will be required to make payment of a System Extension Charge at the time of issuance of a permit to connect to the system extension. Such charge shall be determined by multiplying the actual frontage on record for the property in the land records by the System Extension Charge established and in effect in the Department's Schedule of Rates, Charges and Fees at the time of the extension. In the event of a corner lot, the lesser of the two frontages will be used to calculate the System Extension Charge.

The Department will place a caveat in the land records for the affected properties prior to and upon completion of such system extensions.

SECTION 7 – VIOLATIONS

7.01 PENALTIES

Any person found to be in violation of any provisions of these Rules and Regulations shall be served by the Department with written notice stating the nature of the violation and indicating a time limit for the satisfactory correction of the violation. The offender shall, within the period of time stated in such notice, permanently cease all violations. Any such violations shall be reported to the appropriate authorities.

Any person who continues any violation beyond the time limit provided for above may be fined in the amount not exceeding two hundred (\$200.00) dollars for each such violation. Each day in which any such violation shall continue shall be deemed a separate offense.

The Department may, when it deems appropriate and at its sole discretion, pursue legal action against any violators.

The Department may, at its sole discretion, revoke any permits it has issued relative to work for which a violation has been issued.

Any person who is found to be in violation of any of the provisions of these Rules and Regulations shall become liable to the Town of Manchester for any expense, loss or damage incurred by the Town of Manchester by reason of such violation.

In addition to any penalty imposed by the Department, any person who is found to be in violation of Sections 22a-430 and 22a-430(b) of the GSC may be subject to monetary penalty or forfeiture under Section 22a-438 of the GSC.

SECTION 8 – DESIGN AND CONSTRUCTION

8.01 TECHNICAL AND MATERIAL STANDARDS

Design and construction of all water and sanitary sewer facilities, both public and private, within the Department's Water and/or Sanitary Sewer Service Areas and any system extensions shall be in accordance with the criteria and requirements set forth in these Rules and Regulations and the Town of Manchester Public Improvement Standards.

FIGURE 1 WATER SYSTEM

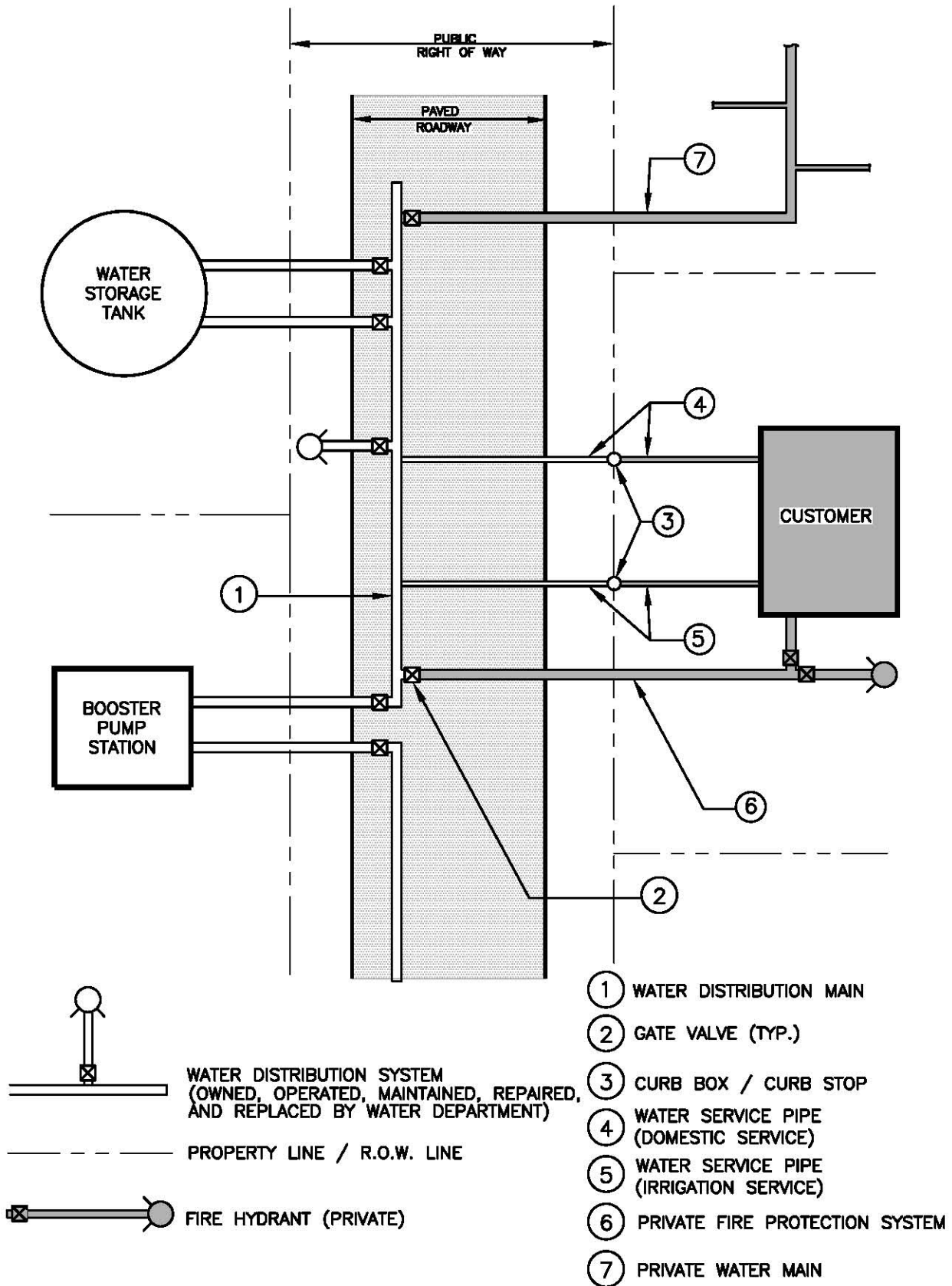
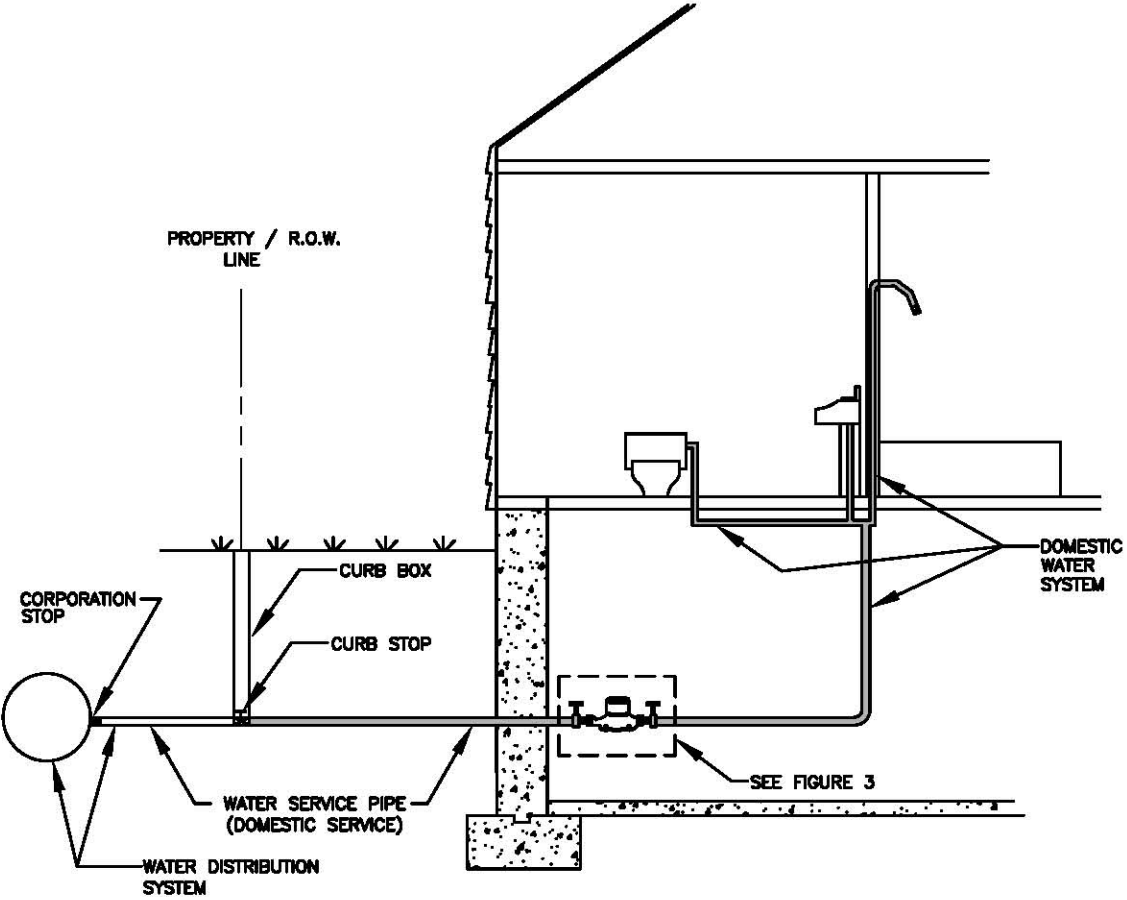
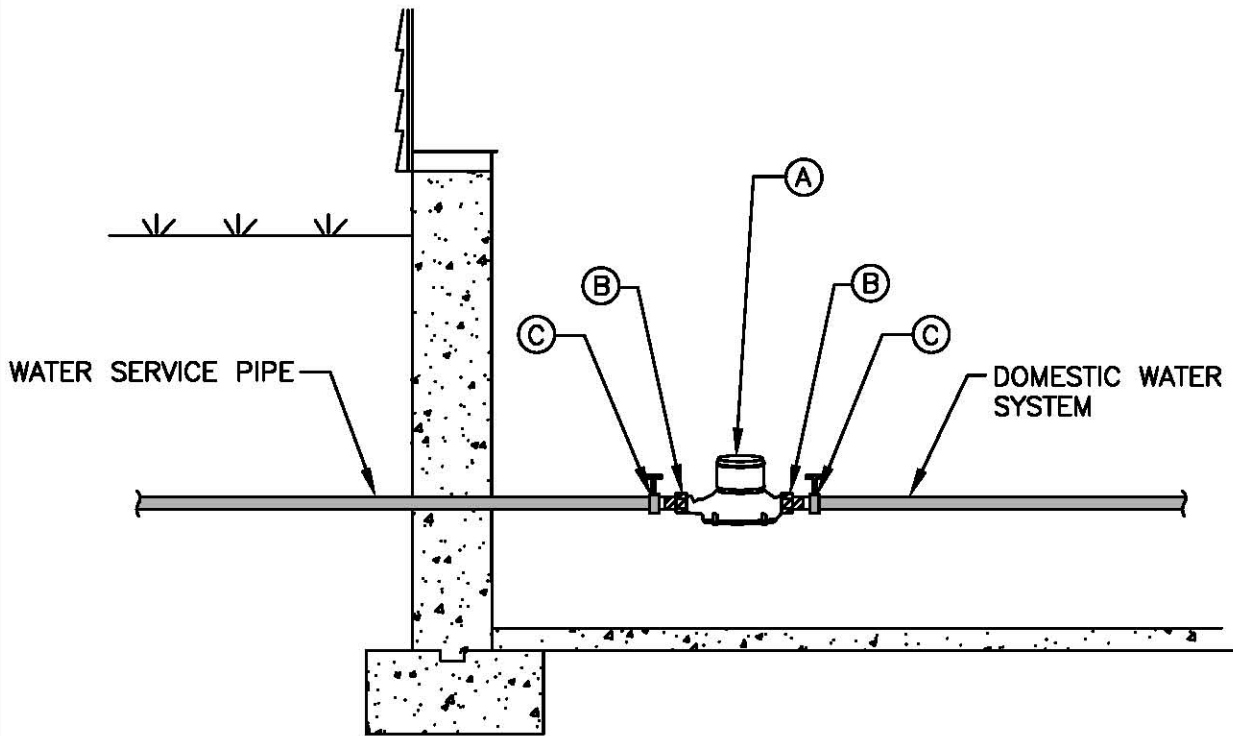

FIGURE 2 WATER SUPPLY SYSTEM



NOTE: THE SHADED PORTIONS OF THE SYSTEM ARE OWNED, OPERATED, MAINTAINED, REPAIRED, AND REPLACED BY THE OWNER

FIGURE 3 WATER METER WITH APPURTENANCES



- Ⓐ METER & ASSOCIATED READING EQUIPMENT.... OWNED, OPERATED, MAINTAINED, REPAIRED, AND REPLACED BY WATER DEPARTMENT
- Ⓑ TAILPIECE..... OWNED, OPERATED, MAINTAINED, REPAIRED, AND REPLACED BY WATER DEPARTMENT
- Ⓒ ISOLATION VALVE (BALL-TYPE)..... OWNED, OPERATED, MAINTAINED, REPAIRED, AND REPLACED BY OWNER

FIGURE 4 PRIVATE FIRE PROTECTION SYSTEM

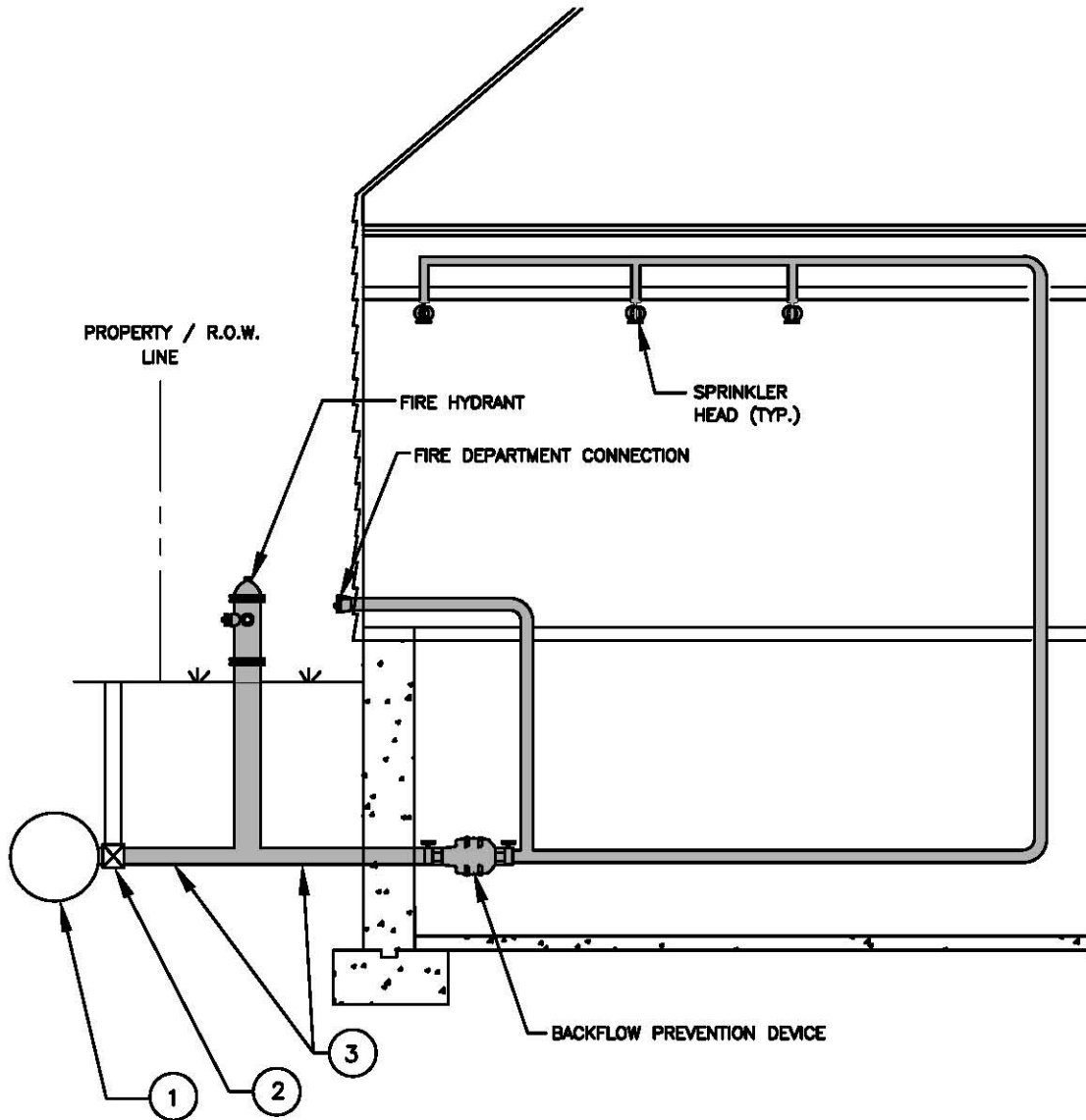

- ① WATER DISTRIBUTION SYSTEM
- ② GATE VALVE (COMMERCIAL)
CURB STOP (RESIDENTIAL)
- ③ WATER SERVICE PIPE
(FIRE SERVICE)

NOTE: SHADED PORTIONS OF THE SYSTEM CONSTITUTE THE PRIVATE FIRE PROTECTION SYSTEM* AND ARE OWNED, OPERATED, MAINTAINED, REPAIRED, AND REPLACED BY THE OWNER.

* COMMERCIAL OR RESIDENTIAL

FIGURE 5 IRRIGATION SERVICE

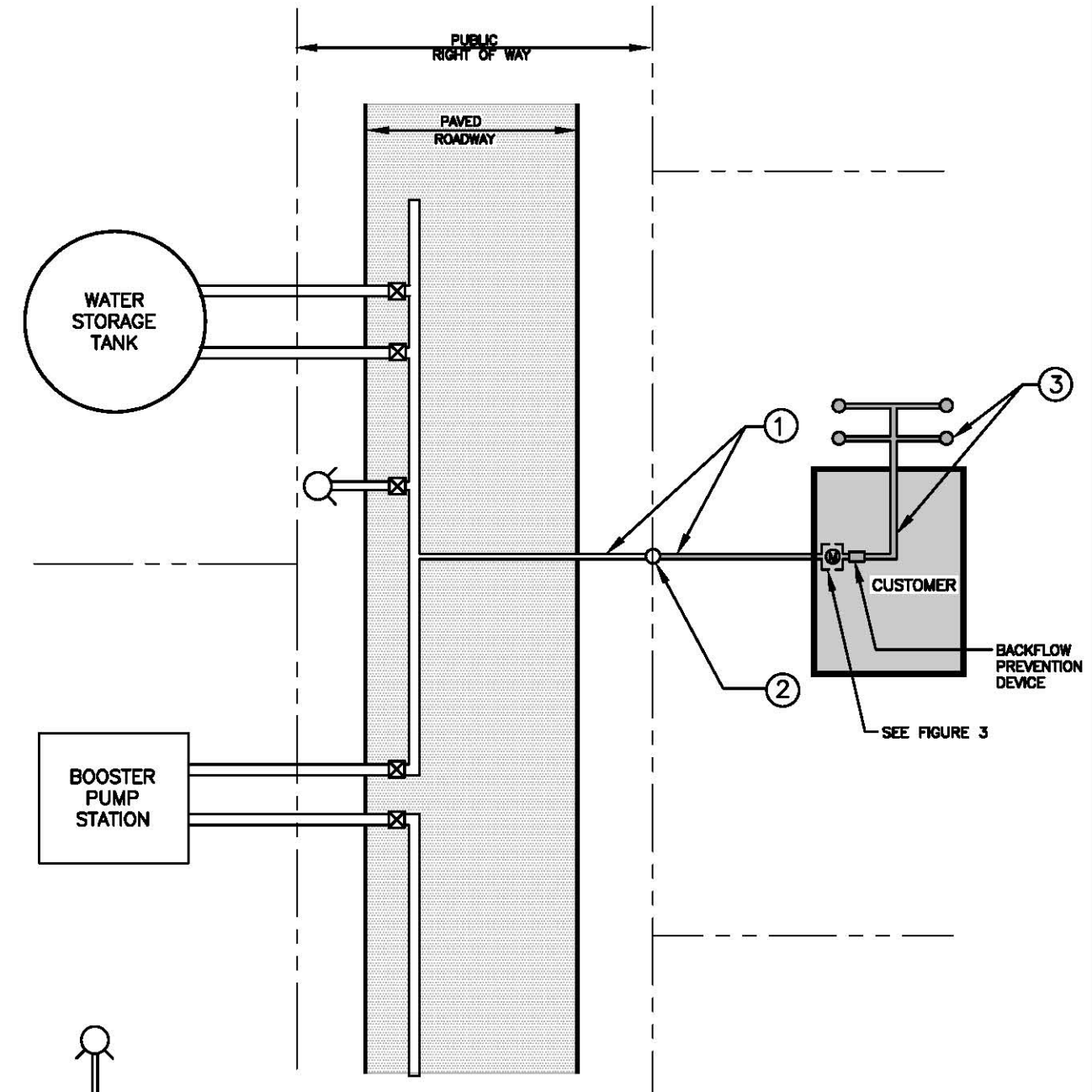

 WATER DISTRIBUTION SYSTEM
(OWNED, OPERATED, MAINTAINED, REPAIRED,
AND REPLACED BY WATER DEPARTMENT)

----- PROPERTY LINE / R.O.W. LINE

- ① WATER SERVICE PIPE (IRRIGATION SERVICE)
- ② CURB STOP / CURB BOX
- ③ IRRIGATION SYSTEM

NOTES: THE SHADED PORTIONS OF THE IRRIGATION SERVICE AND SYSTEM, INCLUDING THE BACKFLOW PREVENTION DEVICE, ARE OWNED, OPERATED, MAINTAINED, REPAIRED, AND REPLACED BY THE OWNER.

FIGURE 6 SANITARY SEWER SYSTEM

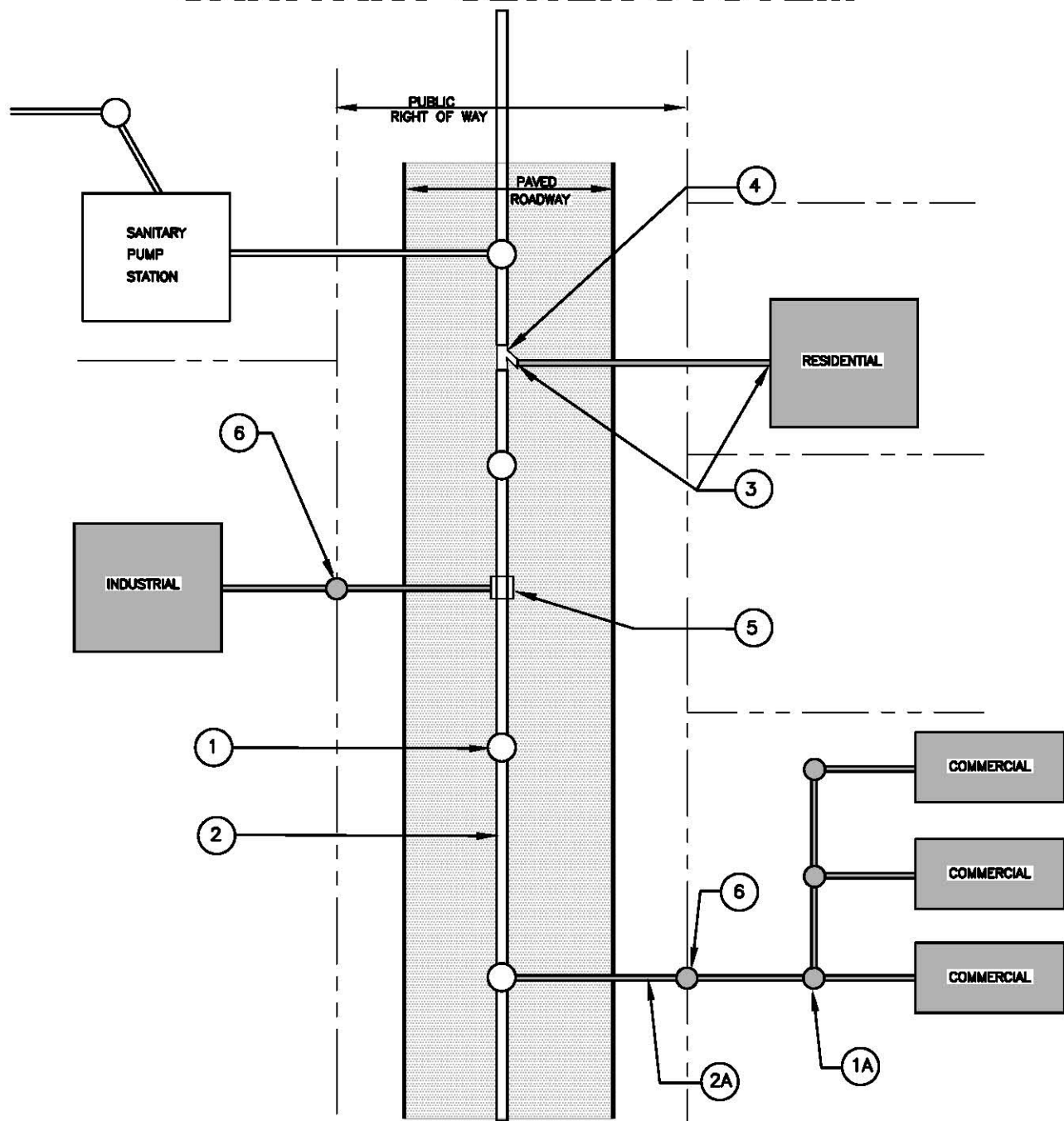



- | | | | |
|--|--|--|---|
|  <p>SANITARY SEWER COLLECTION SYSTEM
(OWNED, OPERATED, MAINTAINED, REPAIRED,
AND REPLACED BY MANCHESTER SEWER
DEPARTMENT)</p> |  <p>SANITARY SEWER WYE, TEE/WYE, SADDLE
OR CHIMNEY OWNED, OPERATED, REPAIRED,
AND REPLACED BY THE MANCHESTER
SEWER DEPARTMENT (BUT MAINTAINED
BY THE OWNER)</p> |  <p>PROPERTY LINE / R.O.W. LINE</p> | <p>① SANITARY SEWER MANHOLE (PUBLIC)</p> <p>①A SANITARY SEWER MANHOLE (PRIVATE)</p> <p>② SANITARY SEWER MAIN (PUBLIC)</p> <p>②A SANITARY SEWER MAIN (PRIVATE)</p> <p>③ SANITARY SEWER LATERAL
(PRIVATE - SEE FIGURE 7)</p> <p>④ SANITARY SEWER WYE, TEE/WYE, SADDLE</p> <p>⑤ SANITARY SEWER CHIMNEY</p> <p>⑥ SANITARY SEWER MANHOLE FOR INSPECTIONS
(PRIVATE)</p> |
|--|--|--|---|

FIGURE 7 SANITARY SEWER LATERAL

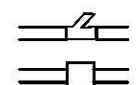
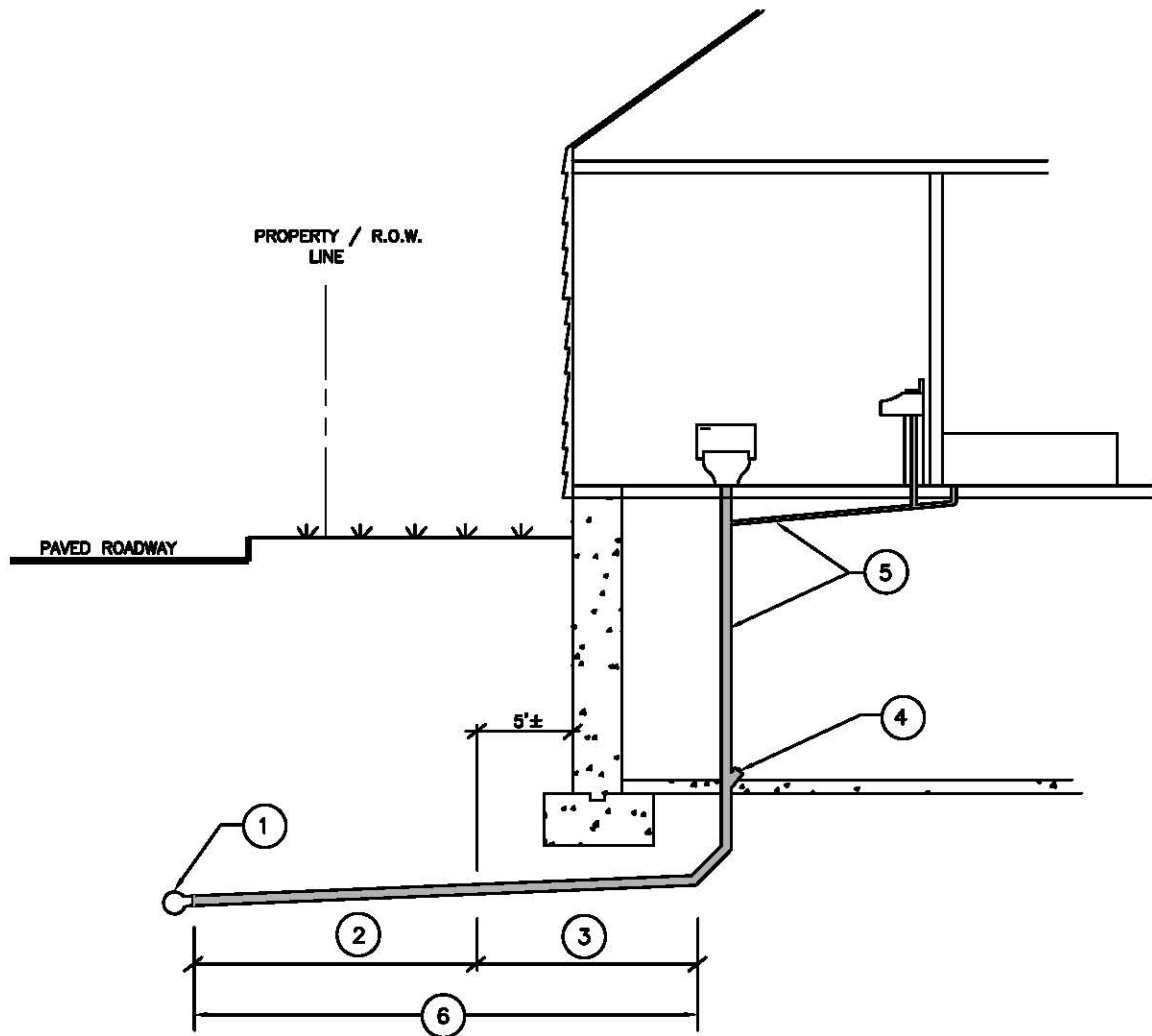

NOTE: THE SHADED PORTIONS OF THE SYSTEM CONSTITUTE THE SANITARY SEWER LATERAL AND THE DOMESTIC WASTEWATER SYSTEM AND ARE OWNED, OPERATED, MAINTAINED, REPAIRED, AND REPLACED BY THE OWNER

- | | |
|-----------------------|------------------------------|
| ① SANITARY SEWER MAIN | ④ CLEANOUT |
| ② BUILDING SEWER | ⑤ DOMESTIC WASTEWATER SYSTEM |
| ③ BUILDING DRAIN | ⑥ SANITARY SEWER LATERAL |